

**BASIC INSTRUMENTATION  
MEASURING DEVICES  
AND  
BASIC PID CONTROL**

## Table of Contents

Section 1 - OBJECTIVES .....	3
Section 2 - INSTRUMENTATION EQUIPMENT .....	7
2.0 INTRODUCTION .....	7
2.1 PRESSURE MEASUREMENT .....	7
2.1.1 General Theory .....	7
2.1.2 Pressure Scales .....	7
2.1.3 Pressure Measurement .....	8
2.1.4 Common Pressure Detectors .....	9
2.1.5 Differential Pressure Transmitters .....	11
2.1.6 Strain Gauges .....	13
2.1.7 Capacitance Capsule .....	14
2.1.8 Impact of Operating Environment .....	15
2.1.9 Failures and Abnormalities .....	16
2.2 FLOW MEASUREMENT .....	18
2.2.1 Flow Detectors .....	18
2.2.2 Square Root Extractor .....	25
2.2.3 Density Compensating Flow Detectors .....	29
2.2.4 Flow Measurement Errors .....	31
2.3 LEVEL MEASUREMENT .....	33
2.3.1 Level Measurement Basics .....	33
2.3.2 Three Valve Manifold .....	34
2.3.3 Open Tank Measurement .....	36
2.3.4 Closed Tank Measurement .....	36
2.3.5 Bubbler Level Measurement System .....	42
2.3.6 Effect of Temperature on Level Measurement .....	44
2.3.7 Effect of Pressure on Level Measurement .....	47
2.3.8 Level Measurement System Errors .....	47
2.4 TEMPERATURE MEASUREMENT .....	49
2.4.1 Resistance Temperature Detector (RTD) .....	49
2.4.2 Thermocouple (T/C) .....	52
2.4.3 Thermal Wells .....	54
2.4.4 Thermostats .....	55
2.5 NEUTRON FLUX MEASUREMENT .....	59
2.5.1 Neutron Flux Detection .....	59
2.5.2 Neutron Detection Methods .....	60
2.5.3 Start-up (sub-critical) Instrumentation .....	61
2.5.4 Fission neutron detectors .....	63
2.5.5 Ion chamber neutron detectors .....	64
2.5.6 In-Core Neutron Detectors .....	70
2.5.7 Reactor Control at High Power .....	77
2.5.8 Overlap of Neutron Detection .....	78
REVIEW QUESTIONS - EQUIPMENT .....	81

Section 3 - CONTROL .....	89
3.0 INTRODUCTION .....	89
3.1 BASIC CONTROL PRINCIPLES .....	89
3.1.1 Feedback Control.....	91
3.1.2 Feedforward Control.....	91
3.1.3 Summary.....	92
3.2 ON/OFF CONTROL .....	93
3.2.1 Summary.....	94
3.3 BASIC PROPORTIONAL CONTROL .....	95
3.3.1 Summary.....	97
3.4 Proportional Control .....	98
3.4.1 Terminology.....	98
3.4.2 Practical Proportional Control .....	98
3.4.3 Summary.....	105
3.5 Reset of Integral Action.....	106
3.5.1 Summary.....	109
3.6 RATE OR DERIVATIVE ACTION .....	110
3.6.1 Summary.....	115
3.7 MULTIPLE CONTROL MODES.....	116
3.8 TYPICAL NEGATIVE FEEDBACK CONTROL SCHEMES	117
3.8.1 Level Control .....	117
3.8.2 Flow Control.....	118
3.8.3 Pressure Control.....	119
3.8.4 Temperature Control.....	120
REVIEW QUESTIONS - CONTROL .....	122

## OBJECTIVES

Note

This module covers the following areas pertaining to instrumentation and control.

- Pressure
- Flow
- Level
- Temperature
- Neutron Flux
- Control

At the end of training the participants will be able to:

### Pressure

- explain the basic working principle of pressure measuring devices, bourdon tube, bellows, diaphragm, capsule, strain gauge, capacitance capsule;
- explain the basic operation of a differential pressure transmitter;
- explain the effects of operating environment (pressure, temperature, humidity) on pressure detectors;
- state the effect of the following failures or abnormalities:
  - over-pressuring a differential pressure cell or bourdon tube;
  - diaphragm failure in a differential pressure cell;
  - blocked or leaking sensing lines; and
  - loss of loop electrical power.

### Flow

- explain how devices generate a differential pressure signal: orifice, venturi, flow nozzle, elbow, pitot tube, annubar;
- explain how each of the following will affect the indicated flow signal from each of the above devices:
  - change in process fluid temperature;
  - change in process fluid pressure; and
  - erosion.
- identify the primary device, three-valve manifold and flow transmitter in a flow measurement installation;
- state the relationship between fluid flow and output signal in a flow control loop with a square root extractor;
- describe the operation of density compensating flow detectors;
- explain why density compensation is required in some flow measurements;
- state the effect on the flow measurement in process with abnormalities: Vapour formation in the throat, clogging of throat by foreign material, Leaks in HI or LO pressure sensing lines;

### Level

- explain how a level signal is derived for: an open vessel, a closed vessel with dry reference leg, a closed vessel with wet reference leg;
- explain how a DP cell can be damaged from over pressure if it is not isolated correctly;
- explain how a bubbler derives level signal for an open and closed tank;
- explain the need for zero suppression and zero elevation in level measurement installations;
- describe the effects of varying liquid temperature or pressure on level indication from a differential pressure transmitter;
- explain how errors are introduced into the DP cell signal by abnormalities: leaking sensing lines, dirt or debris in the sensing lines;

### Temperature

- explain the principle of operation of temperature detectors: RTD, thermocouple, bimetallic strip & pressure cylinders;
- state the advantages and disadvantages of RTDs and thermocouples
- state the effect on the indicated temperature for failures, open circuit and short circuit;

### Flux

- state the reactor power control range for different neutron sensors and explain why overlap is required: Start-up instrumentation, Ion Chambers, In Core detectors;
- explain how a neutron flux signal is derived in a  $\text{BF}_3$  proportional counter;
- explain the reasons for start-up instrumentation burn-out;
- explain how a neutron flux signal is derived in an ion chamber;
- state the basic principles of operation of a fission chamber radiation detector;
- state and explain methods of gamma discrimination for neutron ion chambers;
- explain how the external factors affect the accuracy of the ion chamber's neutron flux measurement: Low moderator level, Loss of high voltage power supply, Shutdown of the reactor;
- describe the construction and explain the basic operating principle of in-core neutron detectors;
- explain reactor conditions factors can affect the accuracy of the in-core detector neutron flux measurement: Fuelling or reactivity device movement nearby, Start-up of the reactor, long-term exposure to neutron flux, Moderator poison (shielding);

- explain the reasons for power control using ion chambers at low power and in-core detectors at high power;

Note

### Control

- identify the controlled and manipulated variables;
- sketch a simple block diagram and indicate set point, measurement, error, output and disturbances;
- state the difference between open and closed loop control;
- state the basic differences between feedback and feed forward control;
- explain the general on/off control operation;
- explain why a process under on/off control is not controllable at the set point;
- explain why on/off control is suitable for slow responding processes;
- explain the meaning of proportional control in terms of the relationship between the error signal and the control signal;
- explain why offset will occur in a control system, with proportional control only;
- choose the controller action for corrective control;
- convert values of PB in percentage to gain values and vice-versa;
- determine the relative magnitude of offset with respect to the proportional band setting;
- state the accepted system response, i.e.,  $\frac{1}{4}$  decay curve, following a disturbance;
- explain the reason for the use of reset (integral) control and its units;
- sketch the open loop response curve for proportional plus reset control in response to a step disturbance;
- state two general disadvantages of reset control with respect to overall loop stability and loop response if the control setting is incorrectly adjusted;
- calculate the reset action in MPR or RPM given a control system's parameters;
- state, the purpose of rate or derivative control;
- state the units of derivative control;
- justify the use of rate control on slow responding processes such as heat exchangers;
- explain why rate control is not used on fast responding processes.
- sketch the open loop response curve for a control system with proportional plus derivative control modes;
- state which combinations of the control modes will most likely be found in typical control schemes;

- sketch typical control schemes for level, pressure, flow and temperature applications.

Note

## INSTRUMENTATION EQUIPMENT

Note

### 2.0 INTRODUCTION

Instrumentation is the art of measuring the value of some plant parameter, pressure, flow, level or temperature to name a few and supplying a signal that is proportional to the measured parameter. The output signals are standard signal and can then be processed by other equipment to provide indication, alarms or automatic control. There are a number of standard signals; however, those most common in a CANDU plant are the 4-20 mA electronic signal and the 20-100 kPa pneumatic signal.

This section of the course is going to deal with the instrumentation equipment normal used to measure and provide signals. We will look at the measurement of five parameters: pressure, flow, level, temperature, and neutron flux.

### 2.1 PRESSURE MEASUREMENT

This module will examine the theory and operation of pressure detectors (bourdon tubes, diaphragms, bellows, forced balance and variable capacitance). It also covers the variables of an operating environment (pressure, temperature) and the possible modes of failure.

#### 2.1.1 General Theory

Pressure is probably one of the most commonly measured variables in the power plant. It includes the measurement of steam pressure; feed water pressure, condenser pressure, lubricating oil pressure and many more. Pressure is actually the measurement of force acting on area of surface. We could represent this as:

$$\text{Pressure} = \frac{\text{Force}}{\text{Area}} \quad \text{or} \quad P = \frac{F}{A}$$

The units of measurement are either in pounds per square inch (PSI) in British units or Pascals (Pa) in metric. As one PSI is approximately 7000 Pa, we often use kPa and MPa as units of pressure.

#### 2.1.2 Pressure Scales

Before we go into how pressure is sensed and measured, we have to establish a set of ground rules. Pressure varies depending on altitude above sea level, weather pressure fronts and other conditions.

The measure of pressure is, therefore, relative and pressure measurements are stated as either gauge or absolute.



Gauge pressure is the unit we encounter in everyday work (e.g., tire ratings are in gauge pressure).

Note

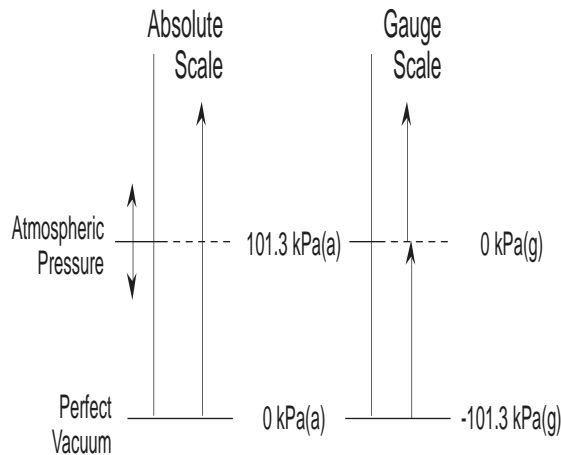
A gauge pressure device will indicate zero pressure when bled down to atmospheric pressure (i.e., gauge pressure is referenced to atmospheric pressure). Gauge pressure is denoted by a (g) at the end of the pressure unit [e.g., kPa (g)].

Absolute pressure includes the effect of atmospheric pressure with the gauge pressure. It is denoted by an (a) at the end of the pressure unit [e.g., kPa (a)]. An absolute pressure indicator would indicate atmospheric pressure when completely vented down to atmosphere - it would not indicate scale zero.

$$\text{Absolute Pressure} = \text{Gauge Pressure} + \text{Atmospheric Pressure}$$

Figure 1 illustrates the relationship between absolute and gauge. Note that the base point for gauge scale is [0 kPa (g)] or standard atmospheric pressure 101.3 kPa (a).

The majority of pressure measurements in a plant are gauge. Absolute measurements tend to be used where pressures are below atmosphere. Typically this is around the condenser and vacuum building.



**Figure 1**

### **Relationship between Absolute and Gauge Pressures**

#### **2.1.3 Pressure Measurement**

The object of pressure sensing is to produce a dial indication, control operation or a standard (4 - 20 mA) electronic signal that represents the pressure in a process.

To accomplish this, most pressure sensors translate pressure into physical motion that is in proportion to the applied pressure. The most common pressure sensors or primary pressure elements are described below.

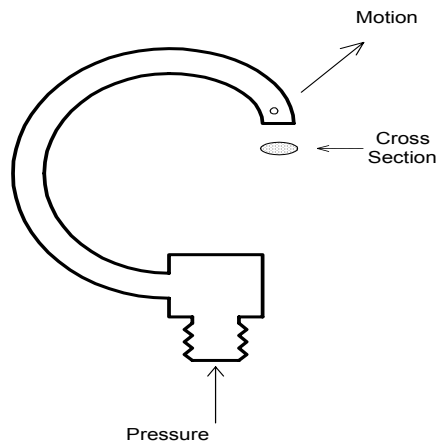
They include diaphragms, pressure bellows, bourdon tubes and pressure capsules. With these pressure sensors, physical motion is proportional to the applied pressure within the operating range.

You will notice that the term differential pressure is often used. This term refers to the difference in pressure between two quantities, systems or devices

### 2.1.4 Common Pressure Detectors

#### Bourdon Tubes

Bourdon tubes are circular-shaped tubes with oval cross sections (refer to Figure 2). The pressure of the medium acts on the inside of the tube. The outward pressure on the oval cross section forces it to become rounded. Because of the curvature of the tube ring, the bourdon tube then bends as indicated in the direction of the arrow.



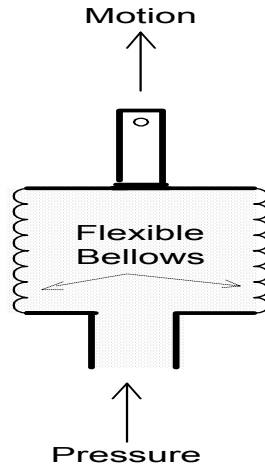
**Figure 2**  
**Bourdon Tube**

Due to their robust construction, bourdon are often used in harsh environments and high pressures, but can also be used for very low pressures; the response time however, is slower than the bellows or diaphragm.

#### Bellows

Bellows type elements are constructed of tubular membranes that are convoluted around the circumference (see Figure 3). The membrane is attached at one end to the source and at the other end to an indicating device or instrument. The bellows element can provide a long range of motion (stroke) in the direction of the arrow when input pressure is applied.

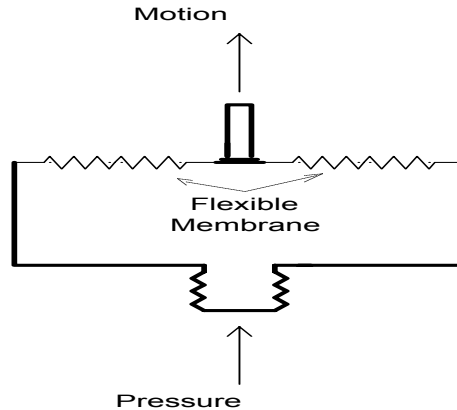
Note



**Figure 3**  
**Bellows**

### Diaphragms

A diaphragm is a circular-shaped convoluted membrane that is attached to the pressure fixture around the circumference (refer to Figure 4). The pressure medium is on one side and the indication medium is on the other. The deflection that is created by pressure in the vessel would be in the direction of the arrow indicated.



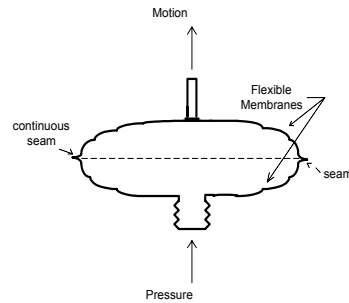
**Figure 4**  
**Diaphragm**

Diaphragms provide fast acting and accurate pressure indication. However, the movement or stroke is not as large as the bellows

### Capsules

There are two different devices that are referred to as capsule. The first is shown in figure 5. The pressure is applied to the inside of the capsule and

if it is fixed only at the air inlet it can expand like a balloon. This arrangement is not much different from the diaphragm except that it expands both ways.



**Figure 5**  
**Capsule**

Note

The capsule consists of two circular shaped, convoluted membranes (usually stainless steel) sealed tight around the circumference. The pressure acts on the inside of the capsule and the generated stroke movement is shown by the direction of the arrow.

The second type of capsule is like the one shown in the differential pressure transmitter (DP transmitter) in figure 7. The capsule in the bottom is constructed with two diaphragms forming an outer case and the inter-space is filled with viscous oil. Pressure is applied to both side of the diaphragm and it will deflect towards the lower pressure.

To provide over-pressurized protection, a solid plate with diaphragm-matching convolutions is usually mounted in the center of the capsule. Silicone oil is then used to fill the cavity between the diaphragms for even pressure transmission.

Most DP capsules can withstand high static pressure of up to 14 MPa (2000 psi) on both sides of the capsule without any damaging effect. However, the sensitive range for most DP capsules is quite low. Typically, they are sensitive up to only a few hundred kPa of differential pressure.

Differential pressure that is significantly higher than the capsule range may damage the capsule permanently.

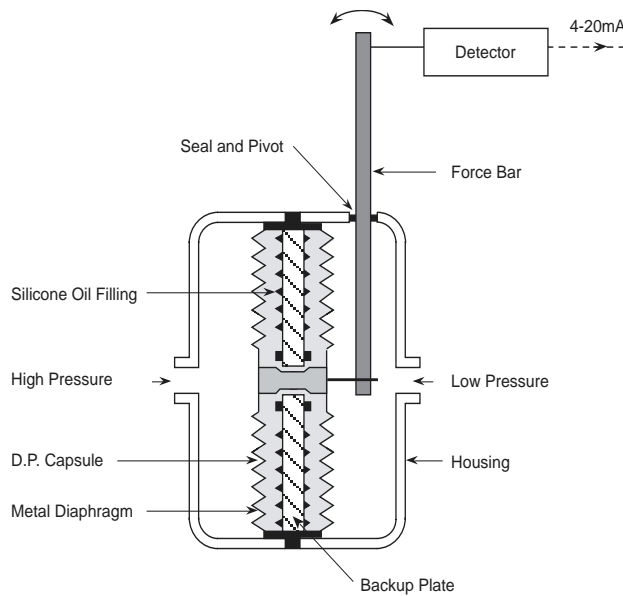
### **2.1.5 Differential Pressure Transmitters**

Most pressure transmitters are built around the pressure capsule concept. They are usually capable of measuring differential pressure (that is, the

difference between a high pressure input and a low pressure input) and therefore, are usually called DP transmitters or DP cells.

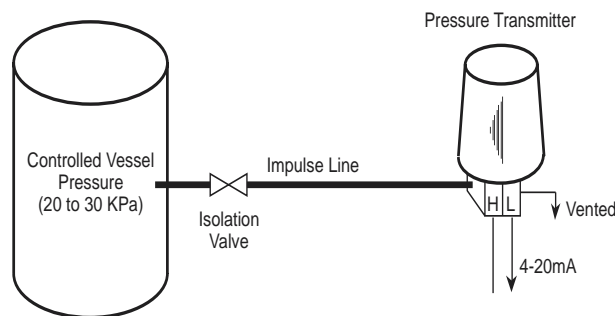
Note

Figure 6 illustrates a typical DP transmitter. A differential pressure capsule is mounted inside a housing. One end of a force bar is connected to the capsule assembly so that the motion of the capsule can be transmitted to outside the housing. A sealing mechanism is used where the force bar penetrates the housing and also acts as the pivot point for the force bar. Provision is made in the housing for high- pressure fluid to be applied on one side of the capsule and low-pressure fluid on the other. Any difference in pressure will cause the capsule to deflect and create motion in the force bar. The top end of the force bar is then connected to a position detector, which via an electronic system will produce a 4 - 20 ma signal that is proportional to the force bar movement.



**Figure 6**  
**Typical DP Transmitter Construction**

This DP transmitter would be used in an installation as shown in Figure 7.



### Figure 7 DP Transmitter Application

Note

A DP transmitter is used to measure the gas pressure (in gauge scale) inside a vessel. In this case, the low-pressure side of the transmitter is vented to atmosphere and the high-pressure side is connected to the vessel through an isolating valve. The isolating valve facilitates the removal of the transmitter.

The output of the DP transmitter is proportional to the gauge pressure of the gas, i.e., 4 mA when pressure is 20 kPa and 20 mA when pressure is 30 kPa.

#### 2.1.6 Strain Gauges

The strain gauge is a device that can be affixed to the surface of an object to detect the force applied to the object. One form of the strain gauge is a metal wire of very small diameter that is attached to the surface of a device being monitored.

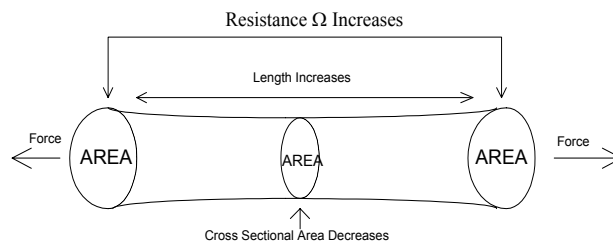


Figure 8  
Strain Gauge

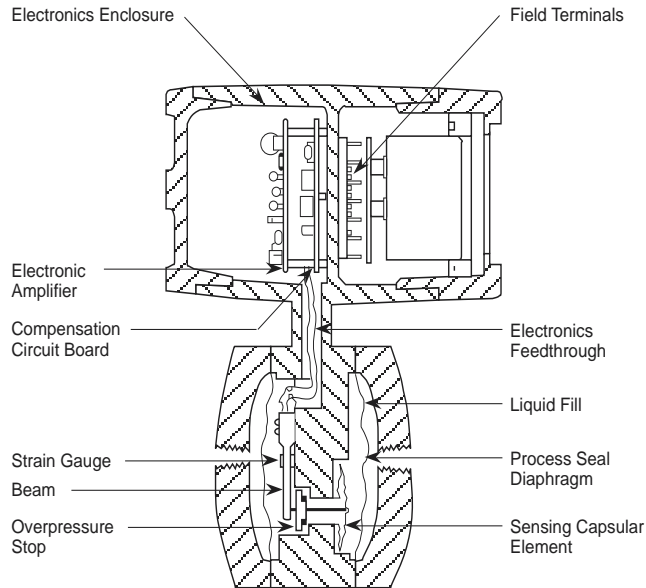
For a metal, the electrical resistance will increase as the length of the metal increases or as the cross sectional diameter decreases.

When force is applied as indicated in Figure 8, the overall length of the wire tends to increase while the cross-sectional area decreases.

The amount of increase in resistance is proportional to the force that produced the change in length and area. The output of the strain gauge is a change in resistance that can be measured by the input circuit of an amplifier.

Strain gauges can be bonded to the surface of a pressure capsule or to a force bar positioned by the measuring element. Shown in Figure 9 (next page) is a strain gauge that is bonded to a force beam inside the DP capsule. The change in the process pressure will cause a resistive change in the strain gauges, which is then used to produce a 4-20 mA signal.

Note



**Figure 9**  
**Resistive Pressure Transmitter**

### 2.1.7 Capacitance Capsule

Similar to the strain gauge, a capacitance cell measures changes in electrical characteristic. As the name implies the capacitance cell measures changes in capacitance. The capacitor is a device that stores electrical charge. It consists of metal plates separated by an electrical insulator. The metal plates are connected to an external electrical circuit through which electrical charge can be transferred from one metal plate to the other.

The capacitance of a capacitor is a measure of its ability to store charge. The capacitance of a capacitor is directly proportional to the area of the metal plates and inversely proportional to the distance between them. It also depends on a characteristic of the insulating material between them. This characteristic, called permittivity is a measure of how well the insulating material increases the ability of the capacitor to store charge.

$$C = \epsilon \frac{A}{d}$$

C is the capacitance in Farads

A is the area of the plates

D is the distance of the plates

$\epsilon$  is the permittivity of the insulator

By building a DP cell capsule so there are capacitors inside the cell capsule, differential pressures can be sensed by the changes in capacitance of the capacitors as the pressure across the cell is varied.

### **2.1.8 Impact of Operating Environment**

All of the sensors described in this module are widely used in control and instrumentation systems throughout the power station.

Their existence will not normally be evident because the physical construction will be enclosed inside manufacturers' packaging. However, each is highly accurate when used to measure the right quantity and within the rating of the device. The constraints are not limited to operating pressure. Other factors include temperature, vapour content and vibration.

#### **Vibration**

The effect of vibration is obvious in the inconsistency of measurements, but the more dangerous result is the stress on the sensitive membranes, diaphragms and linkages that can cause the sensor to fail. Vibration can come from many sources.

Some of the most common are the low level constant vibration of an unbalanced pump impeller and the larger effects of steam hammer. External vibration (loose support brackets and insecure mounting) can have the same effect.

#### **Temperature**

The temperature effects on pressure sensing will occur in two main areas:

The volumetric expansion of vapour is of course temperature dependent. Depending on the system, the increased pressure exerted is usually already factored in.

The second effect of temperature is not so apparent. An operating temperature outside the rating of the sensor will create significant error in the readings. The bourdon tube will indicate a higher reading when exposed to higher temperatures and lower readings when abnormally cold - due to the strength and elasticity of the metal tube. This same effect applies to the other forms of sensors listed.

#### **Vapour Content**

The content of the gas or fluid is usually controlled and known. However, it is mentioned at this point because the purity of the substance whose pressure is being monitored is of importance - whether gaseous or fluid - especially, if the device is used as a differential pressure device in measuring flow of a gas or fluid.

Higher than normal density can force a higher dynamic reading depending on where the sensors are located and how they are used. Also, the vapour density or ambient air density can affect the static pressure sensor readings



and DP cell readings. Usually, lower readings are a result of the lower available pressure of the substance. However, a DP sensor located in a hot and very humid room will tend to read high.

Note

### **2.1.9 Failures and Abnormalities**

#### **Over-Pressure**

All of the pressure sensors we have analyzed are designed to operate over a rated pressure range. Plant operating systems rely on these pressure sensors to maintain high accuracy over that given range. Instrument readings and control functions derived from these devices could place plant operations in jeopardy if the equipment is subjected to over pressure (over range) and subsequently damaged. If a pressure sensor is over ranged, pressure is applied to the point where it can no longer return to its original shape, thus the indication would return to some value greater than the original.

Diaphragms and bellows are usually the most sensitive and fast-acting of all pressure sensors.

They are also however, the most prone to fracture on over-pressuring. Even a small fracture will cause them to read low and be less responsive to pressure changes. Also, the linkages and internal movements of the sensors often become distorted and can leave a permanent offset in the measurement. Bourdon tubes are very robust and can handle extremely high pressures although, when exposed to over-pressure, they become slightly distended and will read high. Very high over-pressuring will of course rupture the tube.

#### **Faulty Sensing Lines**

Faulty sensing lines create inaccurate readings and totally misrepresent the actual pressure

When the pressure lines become partially blocked, the dynamic response of the sensor is naturally reduced and it will have a slow response to change in pressure. Depending on the severity of the blockage, the sensor could even retain an incorrect zero or low reading, long after the change in vessel pressure.

A cracked or punctured sensing line has the characteristic of consistently low readings. Sometimes, there can be detectable down-swings of pressure followed by slow increases.

#### **Loss of Loop Electrical Power**

As with any instrument that relies on AC power, the output of the D/P transmitters will drop to zero or become irrational with a loss of power supply.

Note

## 2.2 FLOW MEASUREMENT

There are various methods used to measure the flow rate of steam, water, lubricants, air, etc., in a nuclear generating station. However, in this module will look at the most common, namely the DP cell type flow detector. Also in this section we will discuss the application of a square root extractor and cut-off relay plus the possible sources of errors in flow measurements and different failure modes that can occur.

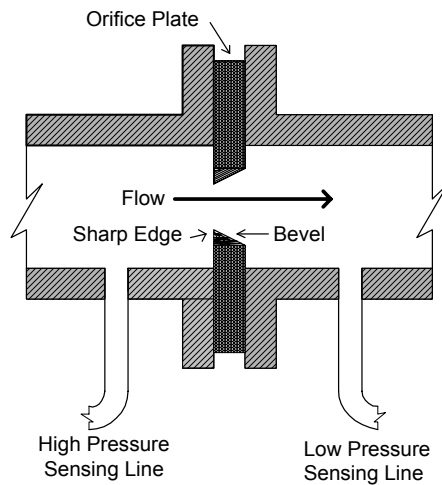
Note

### 2.2.1 Flow Detectors

To measure the rate of flow by the differential pressure method, some form of restriction is placed in the pipeline to create a pressure drop. Since flow in the pipe must pass through a reduced area, the pressure before the restriction is higher than after or downstream. Such a reduction in pressure will cause an increase in the fluid velocity because the same amount of flow must take place before the restriction as after it. Velocity will vary directly with the flow and as the flow increases a greater pressure differential will occur across the restriction. So by measuring the differential pressure across a restriction, one can measure the rate of flow.

#### Orifice Plate

The orifice plate is the most common form of restriction that is used in flow measurement. An orifice plate is basically a thin metal plate with a hole bored in the center. It has a tab on one side where the specification of the plate is stamped. The upstream side of the orifice plate usually has a sharp, edge. Figure 1 shows a representative orifice plate.

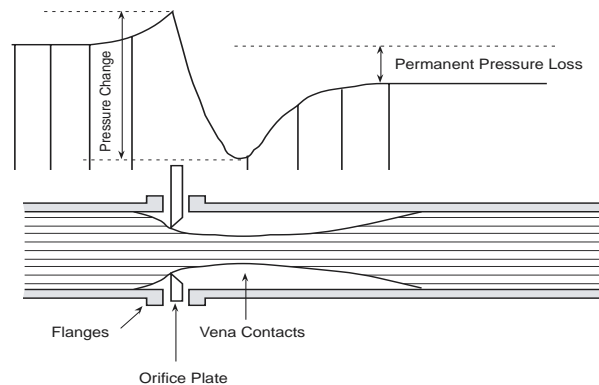


**Figure 1**  
**A Typical Orifice Plate**

Note

When an orifice plate is installed in a flow line (usually clamped between a pair of flanges), increase of fluid flow velocity through the reduced area at the orifice develops a differential pressure across the orifice. This pressure is a function of flow rate.

With an orifice plate in the pipe work, static pressure increases slightly upstream of the orifice (due to back pressure effect) and then decreases sharply as the flow passes through the orifice, reaching a minimum at a point called the vena contracta where the velocity of the flow is at a maximum. Beyond this point, static pressure starts to recover as the flow slows down. However, with an orifice plate, static pressure downstream is always considerably lower than the upstream pressure. In addition some pressure energy is converted to sound and heat due to friction and turbulence at the orifice plate. Figure 2 shows the pressure profile of an orifice plate installation.



**Figure 2**  
**Orifice Plate Installation with Pressure Profile**

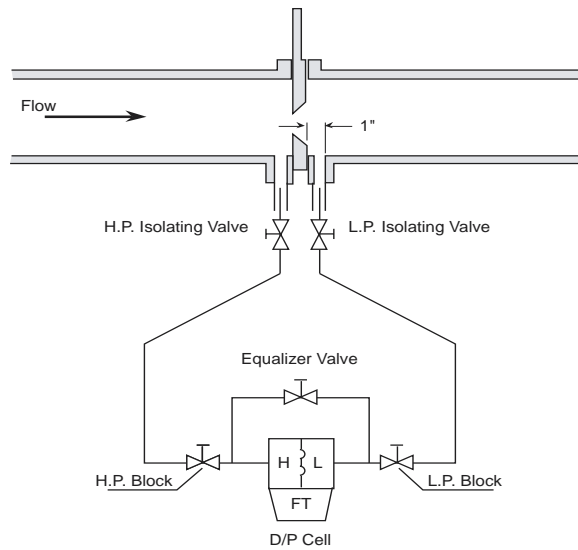
On observing Figure 2, one can see that the measured differential pressure developed by an orifice plate also depends on the location of the pressure sensing points or pressure taps.

### Flange Taps

Flange taps are the most widely used pressure tapping location for orifices. They are holes bored through the flanges, located one inch upstream and one inch downstream from the respective faces of the orifice plate. A typical flange tap installation is shown in Figure 3. The upstream and downstream sides of the orifice plate are connected to the high pressure and low-pressure sides of a DP transmitter. A pressure transmitter, when installed to measure flow, can be called a flow transmitter. As in the case of level measurement, the static pressure in the pipe-work could be many times higher than the differential pressure created by the orifice plate.

Note

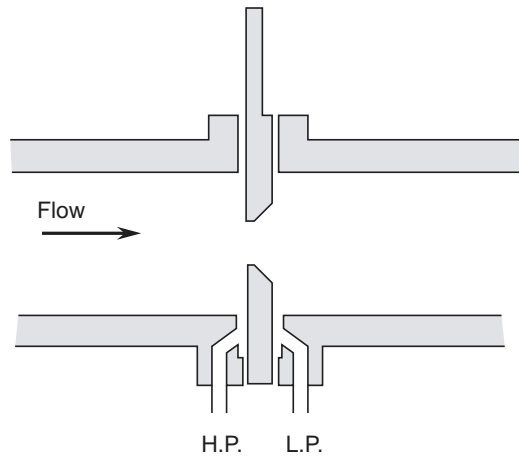
In order to use a capsule that is sensitive to low differential pressure, a three-valve manifold has to be used to protect the DP capsule from being over-ranged. The three valve manifold is discussed in more detail in the section on level measurement.



**Figure 3**  
**Orifice Plate with Flange Taps and Three Valve Manifold**

### Corner Taps

Corner taps are located right at upstream and downstream faces of the orifice plates (see Figure 4).

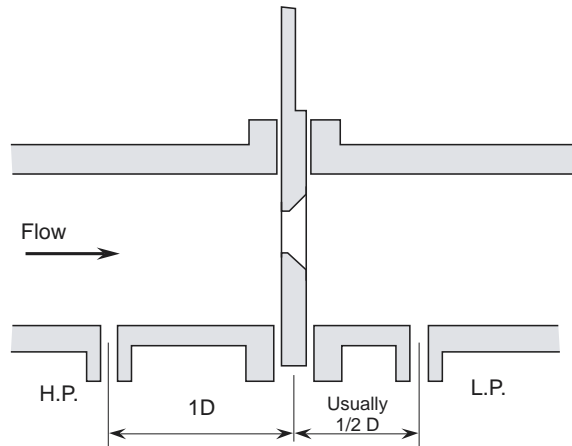


**Figure 4**  
**Orifice Plate with Corner Taps**

### Vena Contracta Taps

Vena contracta taps are located one pipe inner diameter upstream and at the point of minimum pressure, usually one half pipe inner diameter downstream (Figure 5).

Note



**Figure 5**  
**Orifice Plate with Vena Contracta Taps**

### Pipe Taps

Pipe taps are located two and a half pipe inner diameters upstream and eight pipe inner diameters downstream.

When an orifice plate is used with one of the standardized pressure tap locations, an on-location calibration of the flow transmitter is not necessary. Once the ratio and the kind of pressure tap to be used are decided, there are empirically derived charts and tables available to facilitate calibration.

### Advantages and Disadvantages of Orifice Plates

Advantages of orifice plates include:

- High differential pressure generated
- Exhaustive data available
- Low purchase price and installation cost
- Easy replacement

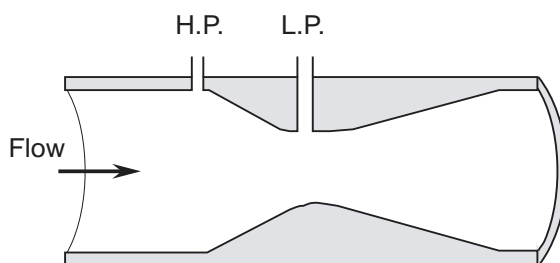
Disadvantages include:

- High permanent pressure loss implies higher pumping cost.
- Cannot be used on dirty fluids, slurries or wet steam as erosion will alter the differential pressure generated by the orifice plate.

Note

### Venturi Tubes

For applications where high permanent pressure loss is not tolerable, a venturi tube (Figure 6) can be used. Because of its gradually curved inlet and outlet cones, almost no permanent pressure drop occurs. This design also minimizes wear and plugging by allowing the flow to sweep suspended solids through without obstruction.



**Figure 6**  
**Venturi Tube Installation**

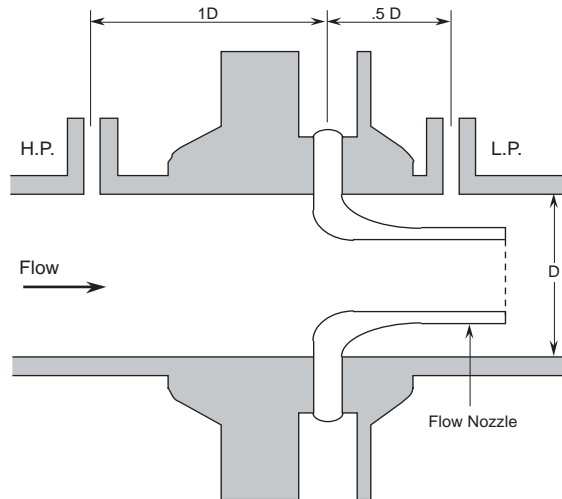
However a Venturi tube does have disadvantages:

- Calculated calibration figures are less accurate than for orifice plates. For greater accuracy, each individual Venturi tube has to be flow calibrated by passing known flows through the Venturi and recording the resulting differential pressures.
- The differential pressure generated by a venturi tube is lower than for an orifice plate and, therefore, a high sensitivity flow transmitter is needed.
- It is more bulky and more expensive.

As a side note; one application of the Venturi tube is the measurement of flow in the primary heat transport system. Together with the temperature change across these fuel channels, thermal power of the reactor can be calculated.

### Flow Nozzle

A flow nozzle is also called a half venturi. Figure 7 shows a typical flow nozzle installation.



**Figure 7**  
**Flow Nozzle Installation**

The flow nozzle has properties between an orifice plate and a venturi. Because of its streamlined contour, the flow nozzle has a lower permanent pressure loss than an orifice plate (but higher than a venturi). The differential it generates is also lower than an orifice plate (but again higher than the venturi tube). They are also less expensive than the venturi tubes.

Flow nozzles are widely used for flow measurements at high velocities. They are more rugged and more resistant to erosion than the sharp-edged orifice plate. An example use of flow nozzles are the measurement of flow in the feed and bleed lines of the PHT system.

### Elbow Taps

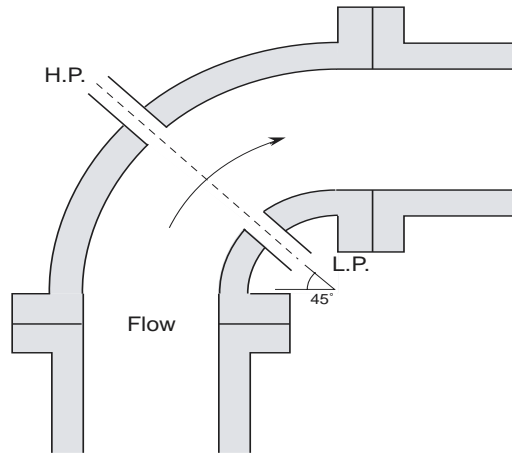
Centrifugal force generated by a fluid flowing through an elbow can be used to measure fluid flow. As fluid goes around an elbow, a high-pressure area appears on the outer face of the elbow. If a flow transmitter is used to sense this high pressure and the lower pressure at the inner face of the elbow, flow rate can be measured. Figure 8 shows an example of an elbow tap installation.

One use of elbow taps is the measurement of steam flow from the boilers, where the large volume of saturated steam at high pressure and temperature could cause an erosion problem for other primary devices.

Another advantage is that the elbows are often already in the regular piping configuration so no additional pressure loss is introduced.

Note



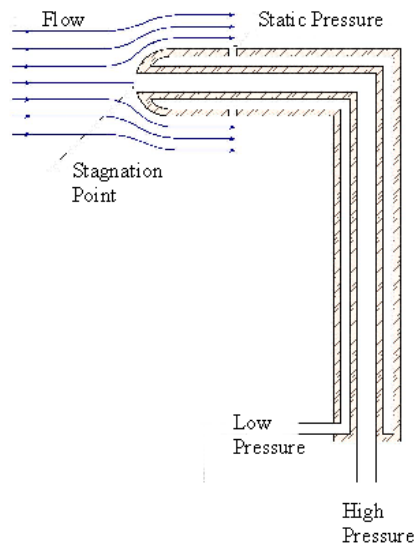


Note

**Figure 8**  
**Elbow Tap Installation**

### Pitot Tubes

Pitot tubes also utilize the principles captured in Bernoulli's equation, to measure flow. Most pitot tubes actually consist of two tubes. One, the low-pressure tube measures the static pressure in the pipe. The second, the high-pressure tube is inserted in the pipe in such a way that the flowing fluid is stopped in the tube. The pressure in the high-pressure tube will be the static pressure in the system plus a pressure dependant on the force required stopping the flow.



**Figure 9**  
**Pitot Tube**

Pitot tubes are more common measuring gas flows than liquid flows. They suffer from a couple of problems.

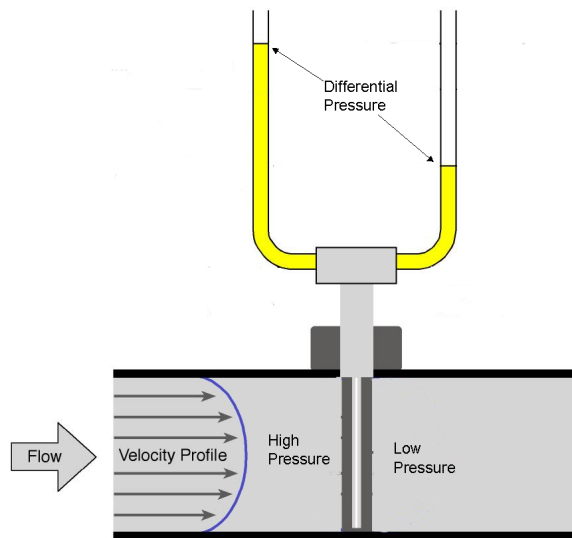
The pressure differential is usually small and hard to measure.

The differing flow velocities across the pipe make the accuracy dependent on the flow profile of the fluid and the position of the pitot in the pipe.

Note

### Annubar

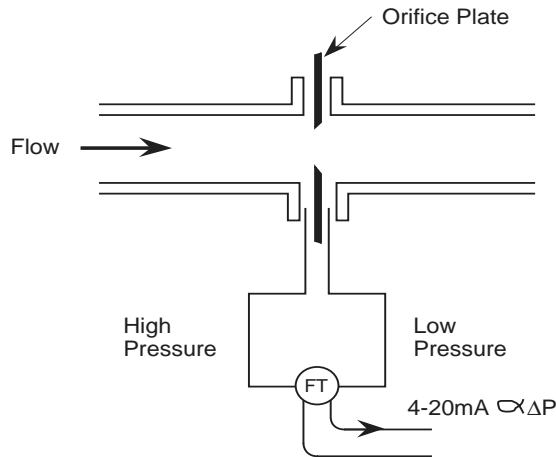
An annubar is very similar to a pitot tube. The difference is that there is more than one hole into the pressure measuring chambers. The pressure in the high-pressure chamber represents an average of the velocity across the pipe. Annubars are more accurate than pitots as they are not as position sensitive or as sensitive to the velocity profile of the fluid.



**Figure 10**  
**Annubar**

### 2.2.2 Square Root Extractor

Up to now, our flow measurement loop can be represented by the installation shown in Figure 9. The high and low-pressure taps of the primary device (orifice type shown) are fed by sensing lines to a differential pressure (D/P) cell. The output of the D/P cell acts on a pressure to milli-amp transducer, which transmits a variable 4-20 ma signal. The D/P cell and transmitter are shown together as a flow transmitter (FT).



Note

**Figure 11**  
**A Flow Loop with Orifice Plate**

This simple system although giving an indication of the flow rate ( $Q$ ), is actually transmitting a signal proportional to the differential pressure ( $\Delta P$ ). However, the relationship between the volume of flow  $Q$  and  $\Delta P$  is not linear. Thus such a system would not be appropriate in instrumentation or metering that requires a linear relationship or scale.

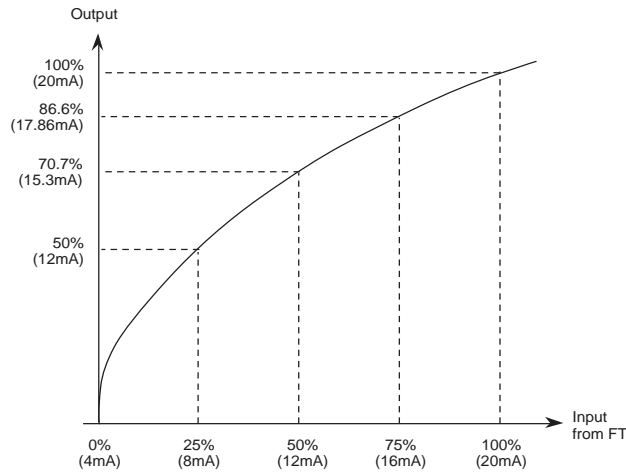
In actuality the differential pressure increases in proportion to the square of the flow rate.

We can write this as:  $\Delta P \propto Q^2$

In other words the flow rate ( $Q$ ) is proportional; to the square root of the differential pressure.

Volumetric Flow Rate =  $Q \propto \sqrt{\Delta P}$

To convert the signal from the flow transmitter, (figure 9 above) to one that is directly proportional to the flow-rate, one has to obtain or extract the square root of the signal from the flow transmitter. Figure 10 illustrates the input - output relationship of a square root extractor.

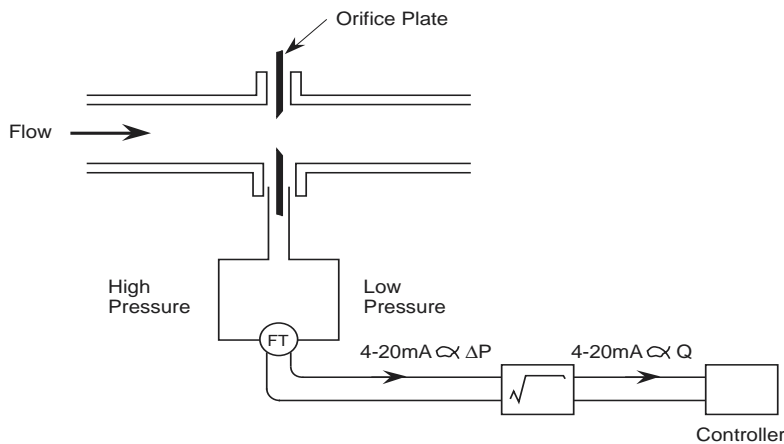


Note

**Figure 12**  
**Square Root Extractor Input and Output**

The square root extractor is an electronic (or pneumatic) device that takes the square root of the signal from the flow transmitter and outputs a corresponding linear flow signal. Several methods are used in the construction of square root extractors. However, it is beyond the scope of this course to discuss the actual circuitries.

A typical square root extractor installation is shown in Figure 13. This system would produce a 4-20-ma signal that is linear with the flow rate.



**Figure 13**

**A Typical Square Root Extractor Installation**

Square root extractors are usually current operated devices so they can be connected directly in the 4-20 mA current loop of a flow transmitter. The output of the square root extractor is again a 4-20 mA signal. This signal is directly proportional to the flow-rate in the pipe-work.

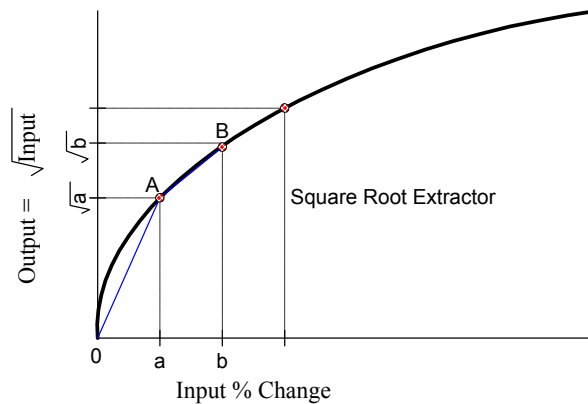
The signal from the square root extractor usually goes to a controller, as shown in Figure 13.

The controller (which can be regarded as an analog computer) is used to control the final control element, usually a valve.

### Cut-off relay

Square root extractors do have a drawback. At low values of input, very small changes in the input (differential pressure) to the extractor will cause a large change in the square root output (flow indication). This system is described as having high gain at values close to zero input. Observe figure 14 below, which is an expanded version of figure 12 at the lower end. The amount of change from zero pressure to A and from A to B is identical. However, for the same input change ( $\Delta P$ ), the gain at low input is greater.

Note



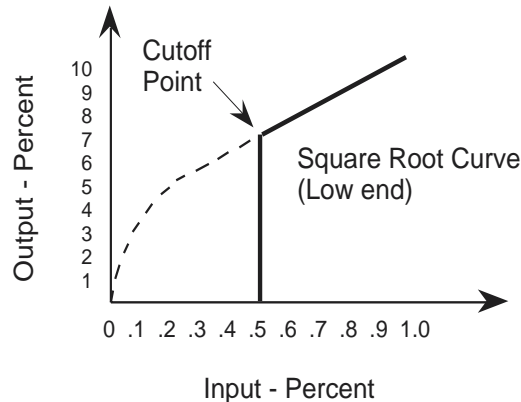
**Figure 14**  
**Square Root Extractor Graph Expanded View**

To illustrate the effect of the very high gain in the square root extractor at low scale values consider a typical situation. A pipe valve is closed and the zero flow produces a 4 mA output from the flow transmitter. If due to noise, temperature or other disturbances, the input drifted from 0% to 1% (i.e., from 4 mA to 4.16 mA), the output would have changed from 0% to 10% (4 mA to 5.6 mA). It is obvious that this significant error sent to the controller has to be eliminated.

For this reason, square root extractors are equipped with cut-off relays. The setting for the relay can be adjusted from 6% to 10% of output. Shown in Figure 15 is a response curve for a cut-off relay set at 7% output. In this case, any input signal below  $(0.07)^2$  or 0.49% would be ignored by the extractor. The output of the extractor would remain at 0% as long as input is below 0.49%.

When the input exceeded 0.49%, the output would resume its normal curve, starting at 7%.

Note



**Figure 15**  
**Response Curve for Extractor with 7% Cut-Off Setting**

### 2.2.3 Density Compensating Flow Detectors

It must be remembered that a DP transmitter used for flow measurement, measures differential pressure, not the volume or mass of flow. We have shown that differential pressure instruments require that the square root differential pressure be taken to obtain volumetric flow  $Q$ :

$$\text{Volume of Flow} = Q \propto \sqrt{\Delta P / \rho}$$

For compressible vapour such as steam, it is more important to know the mass of the flow  $W$  rather than the volume. To determine the mass of a liquid/gas the density ( $\rho = \text{mass per unit volume}$ ) must also be obtained.

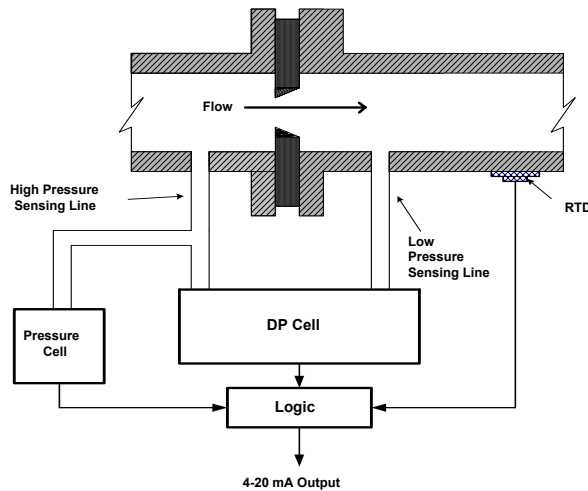
$$\text{Mass of Flow} = W = \rho Q \propto \sqrt{\rho \Delta P}$$

We also know that density varies directly with pressure and inversely with temperature:

$$\rho \propto K \frac{\text{pressure}}{\text{temperature}}$$

The coefficient  $K$  (which can be obtained from tables) depends on a number of variables including the pipe size and the characteristics of the fluid/gas. It is sufficient to say that if the process temperature and static pressure is known, then the density can be obtained.

Note



**Figure 16**  
**Density Compensating Flow Detector**

The density compensating flow detector (shown schematically in figure 16) is a necessity for steam flow between the boilers, re-heaters and the turbines, where the mass (weight) of the steam is more important than the volume.

### Process Conditions

As previously stated, the measurement of flow using any of the devices described above is purely inferential. It relies on the signal from a differential pressure (D/P) cell to obtain an inferred flow measurement. This flow measurement could be either the volume or mass of the liquid/gas. In either case the instrumentation can be affected by the process conditions. The three main parameters are:

### Fluid Temperature

The temperature of the flow quantity has a dramatic effect on the flow measurement. Under the right conditions the liquid can either boil (producing gas pockets and turbulence) or freeze (producing blockages and distorted flow patterns) at the sensors.

At the onset of temperature related flow instrumentation problems the meter readings will become unstable. Gas pockets (causing intermittent low pressure) at the high pressure sensing lines will cause apparent low flow fluctuations. This is more predominant in orifice and flow-nozzle installations. Turbulence at the low-pressure sensor will usually increase as the temperature increases to cause a more stable but incorrect high flow reading.

Note

Temperature also affects the density of the liquid/gas, as per the following relationship (where K is a constant for the liquid/gas).

$$\rho \propto K \frac{\text{pressure}}{\text{temperature}}$$

The mass flow (i.e., pounds of steam per minute) varies inversely with temperature and must be compensated for using a density compensating flow detector.

The elbow tap sensor uses centrifugal force to detect flow and is most sensitive to density changes. The flow readings will increase as the temperature decreases.

### **Fluid Pressure**

As we have just seen, pressure also affects the density of the fluid/gas. For the elbow tap previously mentioned, the flow readings will increase as the process pressure increases.

$$\rho \propto K \frac{\text{pressure}}{\text{temperature}}$$

For all types of D/P flow sensors, mass flow will of course increase as the pressure increases. To obtain the correct measurement of mass flow, a density compensating flow detector must be used as described previously.

### **2.2.4 Flow Measurement Errors**

We have already discussed the pros and cons of each type of flow detector commonly found in a generating station. Some, such as the orifice, are more prone to damage by particulate or saturated steam than others. However, there are common areas where the flow readings can be inaccurate or invalid.

### **Erosion**

Particulate, suspended solids or debris in the piping will not only plug up the sensing lines, it will erode the sensing device. The orifice, by its design with a thin, sharp edge is most affected, but the flow nozzle and even venturi can also be damaged. As the material wears away, the differential pressure between the high and low sides of the sensor will drop and the flow reading will decrease.



### **Over ranging Damage to the D/P Cell**

Again, as previously described, the system pressures are usually much greater than the differential pressure and three valve manifolds must be correctly used.

### **Vapour Formation in the Throat**

D/P flow sensors operate on the relation between velocity and pressure. As gas requires less pressure to compress, there is a greater pressure differential across the D/P cell when the gas expands on the LP side of the sensor. The flow sensor will indicate a higher flow rate than there actually is. The turbulence created at the LP side of the sensor will also make the reading somewhat unstable. A small amount of gas or vapour will make a large difference in the indicated flow rate.

The opposite can occur if the vapour forms in the HP side of the sensor due to cavitation or gas pockets when the fluid approaches the boiling point. In such an instance there will be a fluctuating pressure drop across the D/P cell that will give an erroneously low (or even negative) D/P reading.

### **Clogging of Throat**

Particulate or suspended solids can damage the flow sensor by the high velocities wearing at the flow sensor surfaces. Also, the build-up of material in the throat of the sensor increases the differential pressure across the cell. The error in flow measurement will increase as the flow increases.

### **Plugged or Leaking Sensing Lines**

The effects of plugged or leaking D/P sensing lines is the same as described in previous modules, however the effects are more pronounced with the possible low differential pressures. Periodic maintenance and bleeding of the sensing lines is a must. The instrument error will depend on where the plug/leak is:

On the HP side a plugged or leaking sensing line will cause a lower reading. The reading will become irrational if the LP pressure equals or exceeds the HP sensing pressure.

On the LP side a plugged or leaking sensing line will cause a higher reading.

Note

## 2.3 LEVEL MEASUREMENT

Accurate continuous measurement of volume of fluid in containers has always been a challenge to industry. This is even more so in the nuclear station environment where the fluid could be acidic/caustic or under very high pressure/temperature. We will now examine the measurement of fluid level in vessels and the effect of temperature and pressure on this measurement. We will also consider the operating environment on the measurement and the possible modes of device failure.

Note

### 2.3.1 Level Measurement Basics

Very simple systems employ external sight glasses or tubes to view the height and hence the volume of the fluid. Others utilize floats connected to variable potentiometers or rheostats that will change the resistance according to the amount of motion of the float. This signal is then inputted to transmitters that send a signal to an instrument calibrated to read out the height or volume.

In this module, we will examine the more challenging situations that require inferential level measurement. This technique obtains a level indication indirectly by monitoring the pressure exerted by the height of the liquid in the vessel.

The pressure at the base of a vessel containing liquid is directly proportional to the height of the liquid in the vessel. This is termed hydrostatic pressure. As the level in the vessel rises, the pressure exerted by the liquid at the base of the vessel will increase linearly. Mathematically, we have:

$$P = S \cdot H$$

where

P = Pressure (Pa)

S = Weight density of the liquid ( $\text{N/m}^3$ ) =  $\rho g$

H = Height of liquid column (m)

$\rho$  = Density ( $\text{kg/m}^3$ )

g = acceleration due to gravity ( $9.81 \text{ m/s}^2$ )

The level of liquid inside a tank can be determined from the pressure reading if the weight density of the liquid is constant.

Differential Pressure (DP) capsules are the most commonly used devices to measure the pressure at the base of a tank.

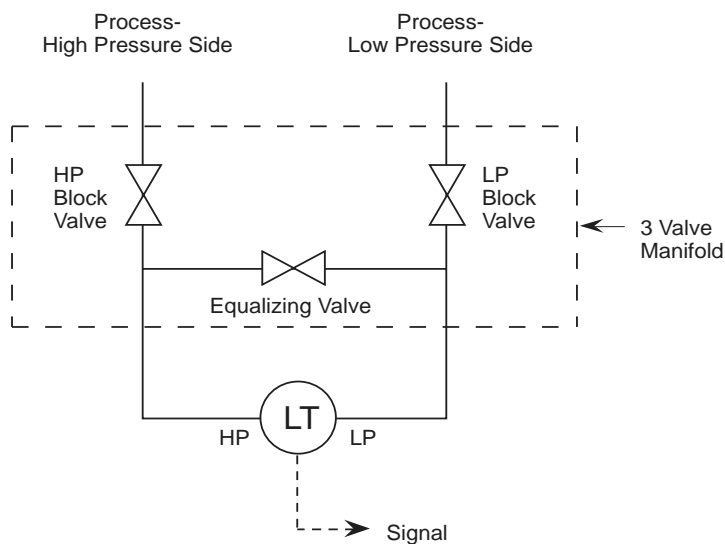
When a DP transmitter is used for the purpose of measuring a level, it will be called a level transmitter.

To obtain maximum sensitivity, a pressure capsule has to be used, that has a sensitivity range that closely matches the anticipated pressure of the measured liquid. However, system pressures are often much higher than the actual hydrostatic pressure that is to be measured. If the process pressure is accidentally applied to only one side of the DP capsule during installation or removal of the DP cell from service, over ranging of the capsule would occur and the capsule could be damaged causing erroneous indications.

Note

### 2.3.2 Three Valve Manifold

A three-valve manifold is a device that is used to ensure that the capsule will not be over-ranged. It also allows isolation of the transmitter from the process loop. It consists of two block valves - high pressure and low-pressure block valve - and an equalizing valve. Figure 1 shows a three valve manifold arrangement.



**Figure 1**  
**A Three Valve Manifold**

During normal operation, the equalizing valve is closed and the two block valves are open. When the transmitter is put into or removed from service, the valves must be operated in such a manner that very high pressure is never applied to only one side of the DP capsule.

### **Operational Sequences of Three-Valve Manifold Valving Transmitter into Service**

To valve a DP transmitter into service an operator would perform the following steps:

1. Check all valves closed.
2. Open the equalizing valve – this ensures that the same pressure will be applied to both sides of the transmitter, i.e., zero differential pressure.
3. Open the High Pressure block valve slowly, check for leakage from both the high pressure and low-pressure side of the transmitter.
4. Close the equalizing valve – this locks the pressure on both sides of the transmitter.
5. Open the low-pressure block valve to apply process pressure to the low-pressure side of the transmitter and establish the working differential pressure.
6. The transmitter is now in service.

Note it may be necessary to bleed any trapped air from the capsule housing.

### **Removing Transmitter from Service**

Reversal of the above steps allows the DP transmitter to be removed from service.

1. Close the low-pressure block valve.
2. Open the equalizing valve.
3. Close the high-pressure block valve.

The transmitter is now out of service.

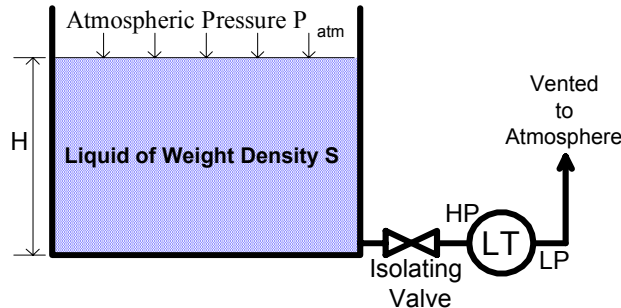
Note the transmitter capsule housing still contains process pressure; this will require bleeding.

Note

### 2.3.3 Open Tank Measurement

The simplest application is the fluid level in an open tank. Figure 2 shows a typical open tank level measurement installation using a pressure capsule level transmitter.

Note



**Figure 2**  
**Open Tank Level Measurement Installation**

If the tank is open to atmosphere, the high-pressure side of the level transmitter will be connected to the base of the tank while the low-pressure side will be vented to atmosphere. In this manner, the level transmitter acts as a simple pressure transmitter. We have:

$$P_{\text{high}} = P_{\text{atm}} + S \cdot H$$

$$P_{\text{low}} = P_{\text{atm}}$$

$$\text{Differential pressure } \Delta P = P_{\text{high}} - P_{\text{low}} = S \cdot H$$

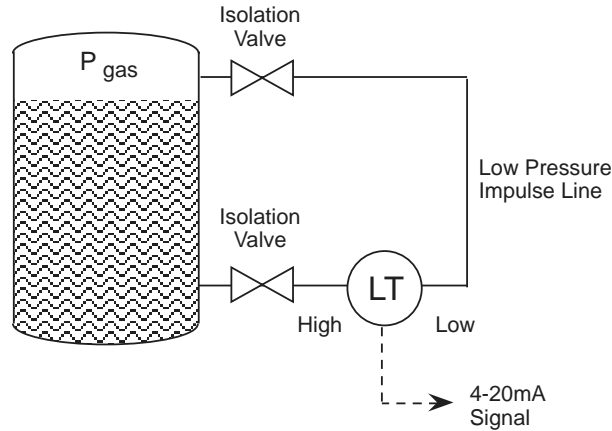
The level transmitter can be calibrated to output 4 mA when the tank is at 0% level and 20 mA when the tank is at 100% level.

### 2.3.4 Closed Tank Measurement

Should the tank be closed and a gas or vapour exists on top of the liquid, the gas pressure must be compensated for. A change in the gas pressure will cause a change in transmitter output. Moreover, the pressure exerted by the gas phase may be so high that the hydrostatic pressure of the liquid column becomes insignificant. For example, the measured hydrostatic head in a CANDU boiler may be only three meters (30 kPa) or so, whereas the steam pressure is typically 5 MPa. Compensation can be achieved by applying the gas pressure to both the high and low-pressure sides of the level transmitter. This cover gas pressure is thus used as a back pressure or reference pressure on the LP side of the DP cell. One can also immediately see the need for the three-valve manifold to protect the DP cell against these pressures.

The different arrangement of the sensing lines to the DP cell is indicated a typical closed tank application (figure 3).

Figure 3 shows a typical closed tank installation.



**Figure 3**  
**Typical Closed Tank Level Measurement System**

We have:

$$P_{\text{high}} = P_{\text{gas}} + S \cdot H$$

$$P_{\text{low}} = P_{\text{gas}}$$

$$\Delta P = P_{\text{high}} - P_{\text{low}} = S \cdot H$$

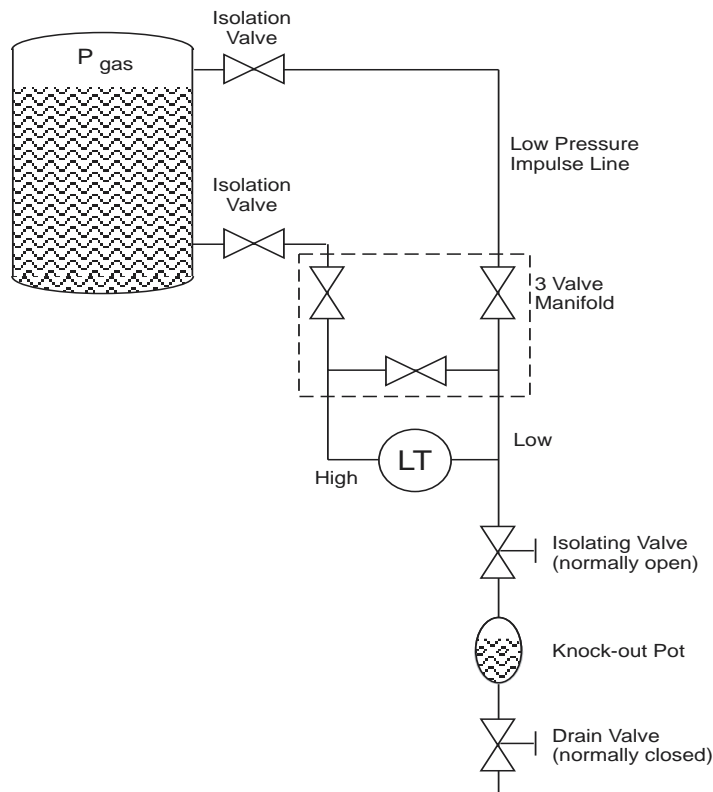
The effect of the gas pressure is cancelled and only the pressure due to the hydrostatic head of the liquid is sensed. When the low-pressure impulse line is connected directly to the gas phase above the liquid level, it is called a dry leg.

Note

## Dry Leg System

A full dry leg installation with three-valve manifold is shown in Figure 4 below.

Note



**Figure 4**  
**Dry Leg Installation with Three-Valve Manifold**

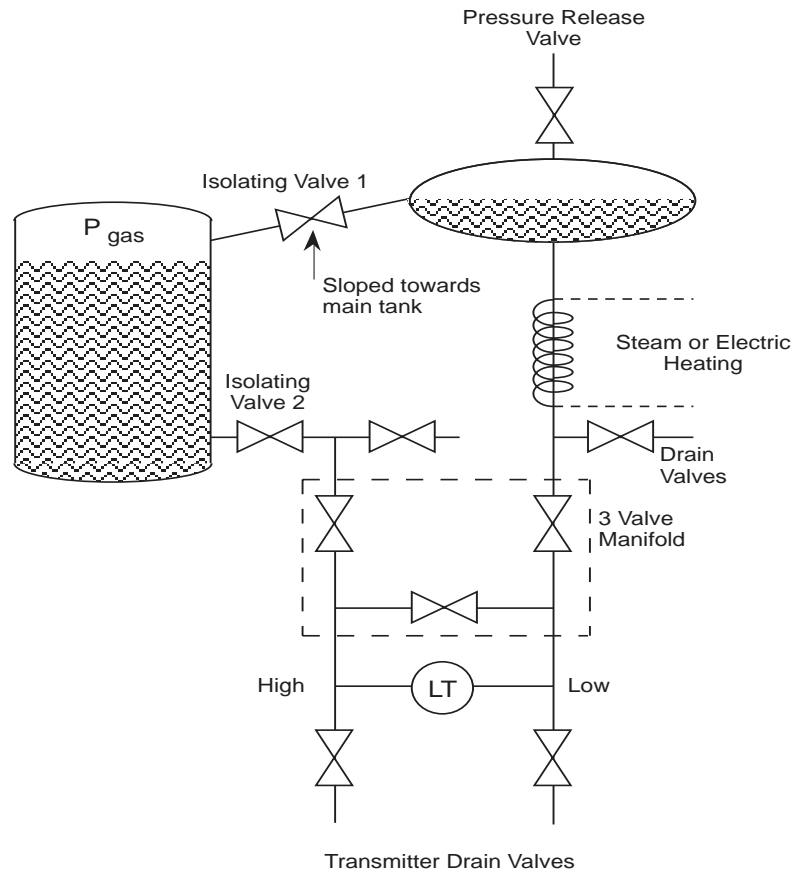
If the gas phase is condensable, say steam, condensate will form in the low-pressure impulse line resulting in a column of liquid, which exerts extra pressure on the low-pressure side of the transmitter. A technique to solve this problem is to add a knockout pot below the transmitter in the low-pressure side as shown in Figure 4. Periodic draining of the condensate in the knockout pot will ensure that the impulse line is free of liquid.

In practice, a dry leg is seldom used because frequent maintenance is required. One example of a dry leg application is the measurement of liquid poison level in the poison injection tank, where the gas phase is non-condensable helium. In most closed tank applications, a wet leg level measurement system is used.

## Wet Leg System

In a wet leg system, the low-pressure impulse line is completely filled with liquid (usually the same liquid as the process) and hence the name wet leg. A level transmitter, with the associated three-valve manifold, is used in an identical manner to the dry leg system.

Figure 5 shows a typical wet leg installation.



**Figure 5**  
**A Wet Leg Installation**

At the top of the low pressure impulse line is a small catch tank. The gas phase or vapour will condense in the wet leg and the catch tank. The catch tank, with the inclined interconnecting line, maintains a constant hydrostatic pressure on the low-pressure side of the level transmitter. This pressure, being a constant, can easily be compensated for by calibration. (Note that operating the three-valve manifold in the prescribed manner helps to preserve the wet leg.)

Note



If the tank is located outdoors, trace heating of the wet leg might be necessary to prevent it from freezing. Steam lines or an electric heating element can be wound around the wet leg to keep the temperature of the condensate above its freezing point.

Note

Note the two sets of drain valves. The transmitter drain valves would be used to drain (bleed) the transmitter only. The two drain valves located immediately above the three-valve manifold are used for impulse and wet leg draining and filling.

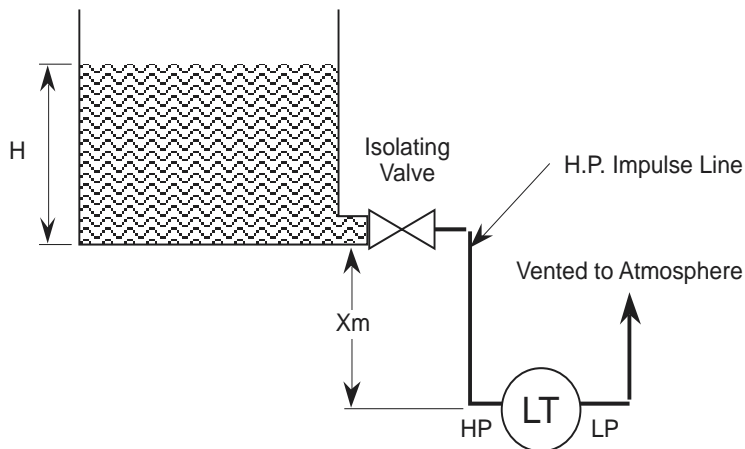
In addition to the three-valve manifold most transmitter installations have valves where the impulse lines connect to the process. These isolating valves, sometimes referred to as the root valves, are used to isolate the transmitter for maintenance.

### Level Compensation

It would be idealistic to say that the DP cell can always be located at the exact the bottom of the vessel we are measuring fluid level in. Hence, the measuring system has to consider the hydrostatic pressure of the fluid in the sensing lines themselves. This leads to two compensations required.

### Zero Suppression

In some cases, it is not possible to mount the level transmitter right at the base level of the tank. Say for maintenance purposes, the level transmitter has to be mounted  $X$  meters below the base of an open tank as shown in Figure 6.



**Figure 6**  
**Level Transmitter with Zero Suppression**

The liquid in the tank exerts a varying pressure that is proportional to its level  $H$  on the high-pressure side of the transmitter. The liquid in the high-pressure impulse line also exerts a pressure on the high-pressure side. However, this pressure is a constant ( $P = S \cdot X$ ) and is present at all times.

Note

When the liquid level is at  $H$  meters, pressure on the high-pressure side of the transmitter will be:

$$P_{\text{high}} = S \cdot H + S \cdot X + P_{\text{atm}}$$

$$P_{\text{low}} = P_{\text{atm}}$$

$$\Delta P = P_{\text{high}} - P_{\text{low}} = S \cdot H + S \cdot X$$

That is, the pressure on the high-pressure side is always higher than the actual pressure exerted by the liquid column in the tank (by a value of  $S \cdot X$ ). This constant pressure would cause an output signal that is higher than 4 mA when the tank is empty and above 20 mA when it is full. The transmitter has to be negatively biased by a value of  $-S \cdot X$  so that the output of the transmitter is proportional to the tank level ( $S \cdot H$ ) only. This procedure is called Zero Suppression and it can be done during calibration of the transmitter. A zero suppression kit can be installed in the transmitter for this purpose.

### Zero Elevation

When a wet leg installation is used (see Figure 7 below), the low-pressure side of the level transmitter will always experience a higher pressure than the high-pressure side. This is due to the fact that the height of the wet leg ( $X$ ) is always equal to or greater than the maximum height of the liquid column ( $H$ ) inside the tank.

When the liquid level is at  $H$  meters, we have:

$$P_{\text{high}} = P_{\text{gas}} + S \cdot H$$

$$P_{\text{low}} = P_{\text{gas}} + S \cdot X$$

$$\begin{aligned} \Delta P &= P_{\text{high}} - P_{\text{low}} = S \cdot H - S \cdot X \\ &= -S(X - H) \end{aligned}$$

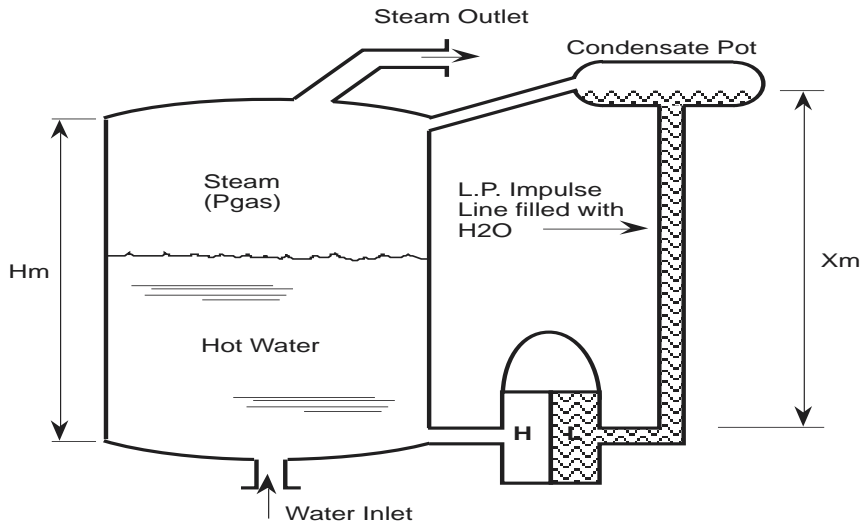
The differential pressure  $\Delta P$  sensed by the transmitter is always a negative number (i.e., low pressure side is at a higher pressure than high pressure side).  $\Delta P$  increases from  $P = -S \cdot X$  to  $P = -S(X-H)$  as the tank level rises from 0% to 100%.

If the transmitter were not calibrated for this constant negative error ( $-S \cdot X$ ), the transmitter output would read low at all times.

To properly calibrate the transmitter, a positive bias ( $+S \cdot X$ ) is needed to elevate the transmitter output.

This positive biasing technique is called zero elevation.

Note



**Figure 7**  
**Requirement for Zero Elevation**

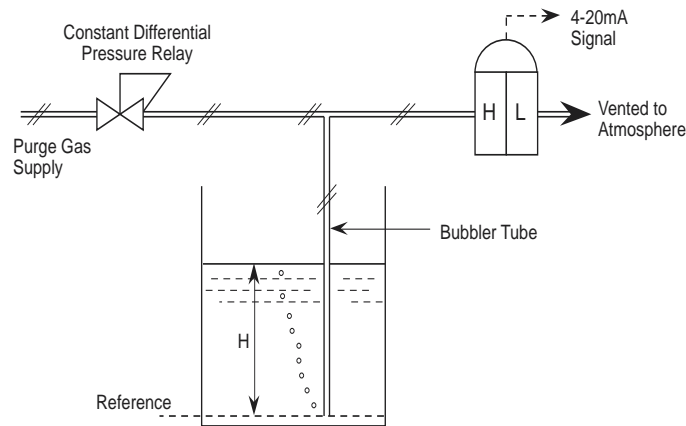
### 2.3.5 Bubbler Level Measurement System

If the process liquid contains suspended solids or is chemically corrosive or radioactive, it is desirable to prevent it from coming into direct contact with the level transmitter. In these cases, a bubbler level measurement system, which utilizes a purge gas, can be used.

## Open Tank Application for Bubbler System

Figure 8 illustrates a typical bubbler system installation.

Note



**Figure 8**  
**Bubbler Level Measurement System in Open Tank Application**

As shown in Figure 8, a bubbler tube is immersed to the bottom of the vessel in which the liquid level is to be measured. A gas (called purge gas) is allowed to pass through the bubbler tube. Consider that the tank is empty. In this case, the gas will escape freely at the end of the tube and therefore the gas pressure inside the bubbler tube (called back pressure) will be at atmospheric pressure. However, as the liquid level inside the tank increases, pressure exerted by the liquid at the base of the tank (and at the opening of the bubbler tube) increases. The hydrostatic pressure of the liquid in effect acts as a seal, which restricts the escape of, purge gas from the bubbler tube.

As a result, the gas pressure in the bubbler tube will continue to increase until it just balances the hydrostatic pressure ( $P = S \cdot H$ ) of the liquid. At this point the backpressure in the bubbler tube is exactly the same as the hydrostatic pressure of the liquid and it will remain constant until any change in the liquid level occurs. Any excess supply pressure will escape as bubbles through the liquid.

As the liquid level rises, the backpressure in the bubbler tube increases proportionally, since the density of the liquid is constant.

A level transmitter (DP cell) can be used to monitor this backpressure. In an open tank installation, the bubbler tube is connected to the high-pressure side of the transmitter, while the low pressure side is vented to atmosphere. The output of the transmitter will be proportional to the tank level.

A constant differential pressure relay is often used in the purge gas line to ensure that constant bubbling action occurs at all tank levels. The constant differential pressure relay maintains a constant flow rate of purge gas in the bubbler tube regardless of tank level variations or supply fluctuation. This ensures that bubbling will occur to maximum tank level and the flow rate does not increase at low tank level in such a way as to cause excessive disturbances at the surface of the liquid. Note that bubbling action has to be continuous or the measurement signal will not be accurate.

Note

An additional advantage of the bubbler system is that, since it measures only the backpressure of the purge gas, the exact location of the level transmitter is not important. The transmitter can be mounted some distance from the process. Open loop bubblers are used to measure levels in spent fuel bays.

### **Closed Tank Application for Bubbler System**

If the bubbler system is to be applied to measure level in a closed tank, some pressure-regulating scheme must be provided for the gas space in the tank. Otherwise, the gas bubbling through the liquid will pressurize the gas space to a point where bubbler supply pressure cannot overcome the static pressure it acts against. The result would be no bubble flow and, therefore, inaccurate measurement signal. Also, as in the case of a closed tank inferential level measurement system, the low-pressure side of the level transmitter has to be connected to the gas space in order to compensate for the effect of gas pressure.

Some typical examples of closed tank application of bubbler systems are the measurement of water level in the irradiated fuel bays and the light water level in the liquid zone control tanks.

### **2.3.6 Effect of Temperature on Level Measurement**

Level measurement systems that use differential pressure  $\Delta P$  as the sensing method, are by their very nature affected by temperature and pressure.

Recall that the measured height  $H$  of a column of liquid is directly proportional to the pressure  $P$  exerted at the base of the column and inversely proportional to the density  $\rho$  of the liquid.

$$H \propto P/\rho$$

Density (mass per unit volume) of a liquid or gas is inversely proportional to its temperature.

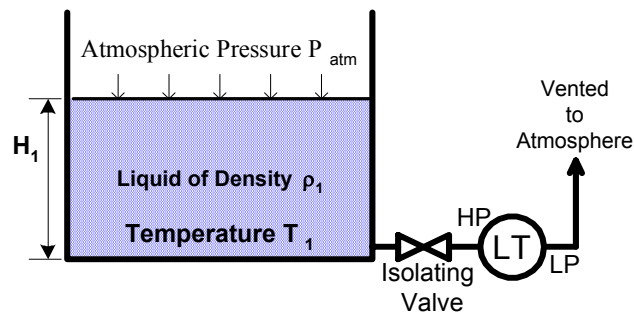
$$\rho \propto 1/T$$

Note

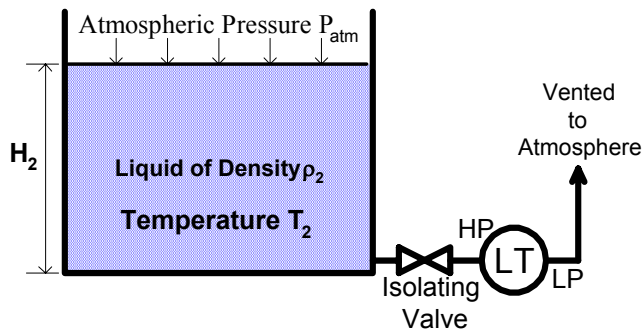
Thus, for any given amount of liquid in a container, the pressure  $P$  exerted at the base will remain constant, but the height will vary directly with the temperature.

$$H \propto T$$

Consider the following scenario. A given amount of liquid in a container [figure 9(a)] is exposed to higher process temperatures [figure 9(b)].



**Figure 9(a)**  
**Low Process Temperature**



**Figure 9(b)**  
**High Process Temperature**

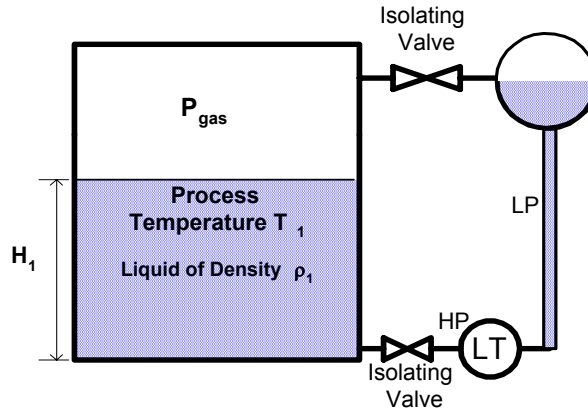
As the amount (mass) of liquid does not change from figure 9(a) to 9(b), the pressure exerted on the base of the container has not changed and the indicated height of the liquid does not change. However, the volume occupied by the liquid has increased and thus the actual height has increased.

The above scenario of figure (9) is a common occurrence in plant operations. Consider a level transmitter calibrated to read correctly at  $75^{\circ}\text{C}$ .

If the process temperature is increased to  $90^{\circ}\text{C}$  as in figure 9 (c), the actual level will be higher than indicated.

The temperature error can also occur in wet-leg systems (figure 10).

Note



**Figure 10**  
**Temperature Effect on Wet-Leg System**

If the reference leg and variable leg are at the same temperature that the level transmitter (LT) is calibrated for, the system will accurately measure liquid level. However, as the process temperature increases, the actual process fluid level increases (as previously discussed), while the indicated measurement remains unchanged.

Further errors can occur if the reference leg and the variable (sensing) leg are at different temperatures. The level indication will have increasing positive (high) error as the temperature of the wet reference leg increases above the variable (process) leg.

As an example, consider temperature changes around a liquid storage tank with a wet leg. As temperature falls and the wet leg cools off, the density of the liquid inside it increases, while the temperature in the tank remains practically unchanged (because of a much bigger volume and connection to the process). As a result the pressure of the reference leg rises and the indicated level decreases. If it happens to the boiler level measurement for a shutdown system it can even lead to an unnecessary reactor trip on boiler low level. However, high-level trips may be prevented under these circumstances. In an extreme case the wet leg may freeze invalidating the measurement scheme completely, but it could be easily prevented with trace heating as indicated earlier (Figure 5).

False high level indication can be caused by an increased wet leg temperature, gas or vapour bubbles or a drained wet leg.

A high measured tank level, with the real level being dangerously low, may prevent the actuation of a safety system on a low value of the trip parameter.

The real level may even get sufficiently low to cause either the cavitation of the pumps that take suction from the tank or gas ingress into the pumps and result in gas locking and a reduced or no flow condition. If the pumps are associated with a safety system like ECI or a safety related system like PHT shutdown cooling, it can lead to possible safety system impairments and increased probability of resultant fuel damage.

### 2.3.7 Effect of Pressure on Level Measurement

Level measurement systems that use differential pressure  $\Delta P$  as the sensing method, are also affected by pressure, although not to the same degree as temperature mentioned in the previous section.

Again the measured height  $H$  of a column of liquid is directly proportional to the pressure  $P_L$  exerted at the base of the column by the liquid and inversely proportional to the density  $\rho$  of the liquid:

$$H \propto P_L / \rho$$

Density (mass per unit volume) of a liquid or gas is directly proportional to the process or system pressure  $P_s$ .

$$\rho \propto P_s$$

Thus, for any given amount of liquid in a container, the pressure  $P_L$  (liquid pressure) exerted at the base of the container by the liquid will remain constant, but the height will vary inversely with the process or system pressure.

$$H \propto 1/P_s$$

Most liquids are fairly incompressible and the process pressure will not affect the level unless there is significant vapour content.

### 2.3.8 Level Measurement System Errors

The level measurement techniques described in this module use inferred processes and not direct measurements. Namely, the indication of fluid level is based on the pressure exerted on a differential pressure (DP) cell by the height of the liquid in the vessel. This places great importance on the physical and environmental problems that can affect the accuracy of this indirect measurement.



## Connections

As amusing as it may sound, many avoidable errors occur because the DP cell had the sensing line connections reversed.

In systems that have high operating pressure but low hydrostatic pressure due to weight of the fluid, this is easy to occur. This is particularly important for closed tank systems.

With an incorrectly connected DP cell the indicated level would go down while the true tank level increases.

## Over-Pressuring

Three valve manifolds are provided on DP cells to prevent over-pressuring and aid in the removal of cells for maintenance. Incorrect procedures can inadvertently over-pressure the differential pressure cell. If the cell does not fail immediately the internal diaphragm may become distorted. The measurements could read either high or low depending on the mode of failure.

Note that if the equalizing valve on the three-valve manifold is inadvertently opened, the level indication will of course drop to a very low level as the pressure across the DP cell equalizes.

## Sensing lines

The sensing lines are the umbilical cord to the DP cell and must be functioning correctly. Some of the errors that can occur are:

### Obstructed sensing lines

The small diameter lines can become clogged with particulate, with resulting inaccurate readings. Sometimes the problem is first noted as an unusually sluggish response to a predicted change in level. Periodic draining and flushing of sensing lines is a must.

### Draining sensing lines

As mentioned previously, the lines must be drained to remove any debris or particulate that may settle to the bottom of the tank and in the line. Also, in closed tank dry leg systems, condensate must be removed regularly to prevent fluid pressure building up on the low-pressure impulse line. Failure to do so will of course give a low tank level reading. Procedural care must be exercised to ensure the DP cell is not over-ranged inadvertently during draining. Such could happen if the block valves are not closed and equalizing valve opened beforehand.

False high level indication can be caused by a leaking or drained wet leg.

A leaking variable (process) leg can cause false low-level indication.

Note

## 2.4 TEMPERATURE MEASUREMENT

Every aspect of our lives, both at home and at work, is influenced by temperature. Temperature measuring devices have been in existence for centuries. The age-old mercury in glass thermometer is still used today and why not? The principle of operation is ageless as the device itself. Its operation was based on the temperature expansion of fluids (mercury or alcohol). As the temperature increased the fluid in a small reservoir or bulb expanded and a small column of the fluid was forced up a tube. You will find the same theory is used in many modern thermostats today. In this module we will look at the theory and operation of some temperature measuring devices commonly found in a generating station. These include thermocouples, thermostats and resistive temperature devices.

Thermocouples (T/C) and resistive temperature devices (RTD) are generally connected to control logic or instrumentation for continuous monitoring of temperature. Thermostats are used for direct positive control of the temperature of a system within preset limits.

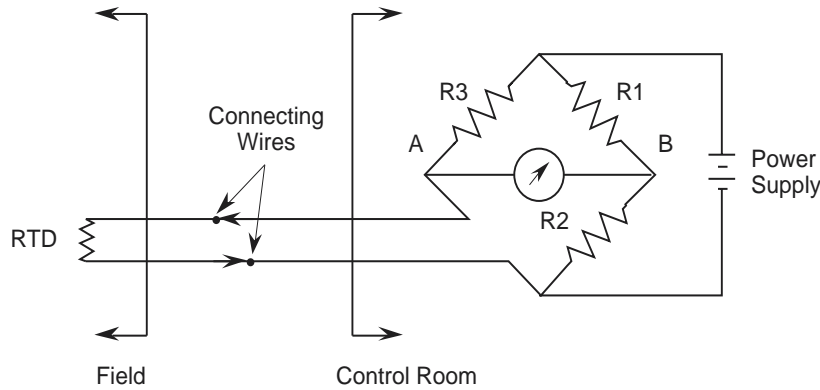
### 2.4.1 Resistance Temperature Detector (RTD)

Every type of metal has a unique composition and has a different resistance to the flow of electrical current. This is termed the resistivity constant for that metal. For most metals the change in electrical resistance is directly proportional to its change in temperature and is linear over a range of temperatures. This constant factor called the temperature coefficient of electrical resistance (short form TCR) is the basis of resistance temperature detectors. The RTD can actually be regarded as a high precision wire wound resistor whose resistance varies with temperature. By measuring the resistance of the metal, its temperature can be determined.

Several different pure metals (such as platinum, nickel and copper) can be used in the manufacture of an RTD. A typical RTD probe contains a coil of very fine metal wire, allowing for a large resistance change without a great space requirement. Usually, platinum RTDs are used as process temperature monitors because of their accuracy and linearity.

To detect the small variations of resistance of the RTD, a temperature transmitter in the form of a Wheatstone bridge is generally used. The circuit compares the RTD value with three known and highly accurate resistors.

Note

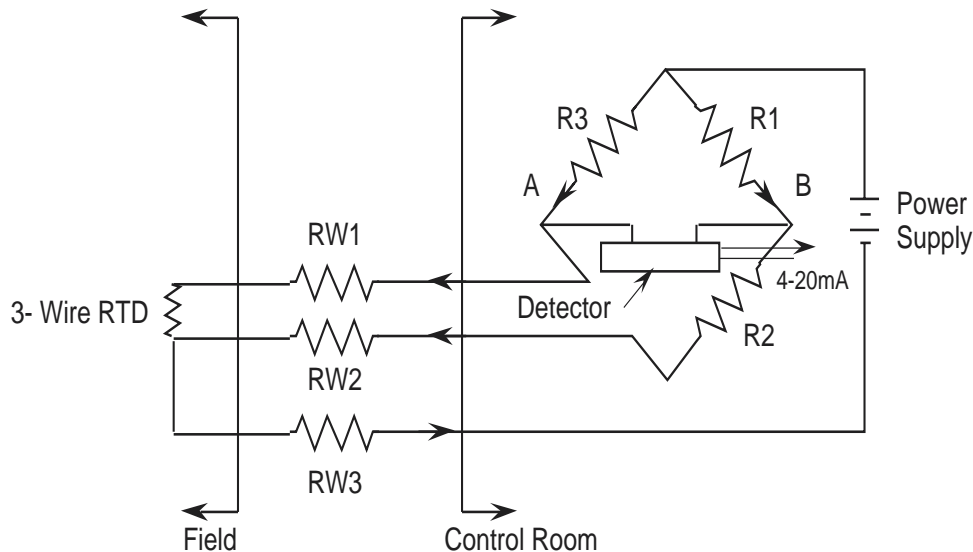


Note

**Figure 1**  
**RTD using a Wheatstone Bridge**

A Wheatstone bridge consisting of an RTD, three resistors, a voltmeter and a voltage source is illustrated in Figure 1. In this circuit, when the current flow in the meter is zero (the voltage at point A equals the voltage at point B) the bridge is said to be in null balance. This would be the zero or set point on the RTD temperature output. As the RTD temperature increases, the voltage read by the voltmeter increases. If a voltage transducer replaces the voltmeter, a 4-20 mA signal, which is proportional to the temperature range being monitored, can be generated.

As in the case of a thermocouple, a problem arises when the RTD is installed some distance away from the transmitter. Since the connecting wires are long, resistance of the wires changes as ambient temperature fluctuates. The variations in wire resistance would introduce an error in the transmitter. To eliminate this problem, a three-wire RTD is used.



**Figure 2**  
**Three-Wired RTD**

Figure 2 illustrates a three-wire RTD installation.

The connecting wires ( $w_1$ ,  $w_2$ ,  $w_3$ ) are made the same length and therefore the same resistance. The power supply is connected to one end of the RTD and the top of the Wheatstone bridge. It can be seen that the resistance of the right leg of the Wheatstone bridge is  $R_1 + R_2 + R_{W2}$ . The resistance of the left leg of the bridge is  $R_3 + R_{W3} + RTD$ . Since  $R_{W1} = R_{W2}$ , the result is that the resistances of the wires cancel and therefore the effect of the connecting wires is eliminated.

### **RTD Advantages and Disadvantages**

#### **Advantages:**

- The response time compared to thermocouples is very fast – in the order of fractions of a second.
- An RTD will not experience drift problems because it is not self-powered.
- Within its range it is more accurate and has higher sensitivity than a thermocouple.
- In an installation where long leads are required, the RTD does not require special extension cable.
- Unlike thermocouples, radioactive radiation (beta, gamma and neutrons) has minimal effect on RTDs since the parameter measured is resistance, not voltage.

#### **Disadvantages:**

- Because the metal used for a RTD must be in its purest form, they are much more expensive than thermocouples.
- In general, an RTD is not capable of measuring as wide a temperature range as a thermocouple.
- A power supply failure can cause erroneous readings
- Small changes in resistance are being measured, thus all connections must be tight and free of corrosion, which will create errors.
- Among the many uses in a nuclear station, RTDs can be found in the reactor area temperature measurement and fuel channel coolant temperature.

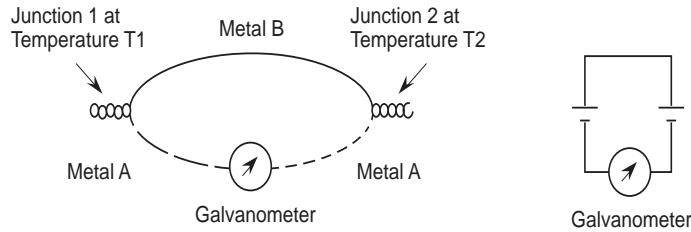
#### **Failure Modes:**

- An open circuit in the RTD or in the wiring between the RTD and the bridge will cause a high temperature reading.
- Loss of power or a short within the RTD will cause a low temperature reading.

### 2.4.2 Thermocouple (T/C)

A thermocouple consists of two pieces of dissimilar metals with their ends joined together (by twisting, soldering or welding). When heat is applied to the junction, a voltage, in the range of milli-volts (mV), is generated. A thermocouple is therefore said to be self-powered. Shown in Figure 3 is a completed thermocouple circuit.

Note



**Figure 3**  
**A Thermocouple Circuit**

The voltage generated at each junction depends on junction temperature. If temperature T1 is higher than T2, then the voltage generated at Junction 1 will be higher than that at Junction 2. In the above circuit, the loop current shown on the galvanometer depends on the relative magnitude of the voltages at the two junctions.

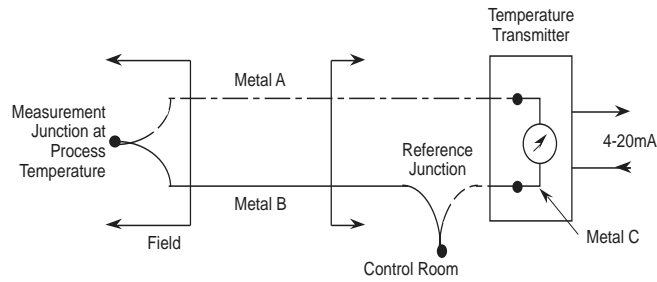
In order to use a thermocouple to measure process temperature, one end of the thermocouple has to be kept in contact with the process while the other end has to be kept at a constant temperature. The end that is in contact with the process is called the hot or measurement junction. The one that is kept at constant temperature is called cold or reference junction. The relationship between total circuit voltage (emf) and the emf at the junctions is:

$$\text{Circuit emf} = \text{Measurement emf} - \text{Reference emf}$$

If circuit emf and reference emf are known, measurement emf can be calculated and the relative temperature determined.

To convert the emf generated by a thermocouple to the standard 4-20 mA signal, a transmitter is needed. This kind of transmitter is called a temperature transmitter. Figure 4 shows a simplified temperature transmitter connection.

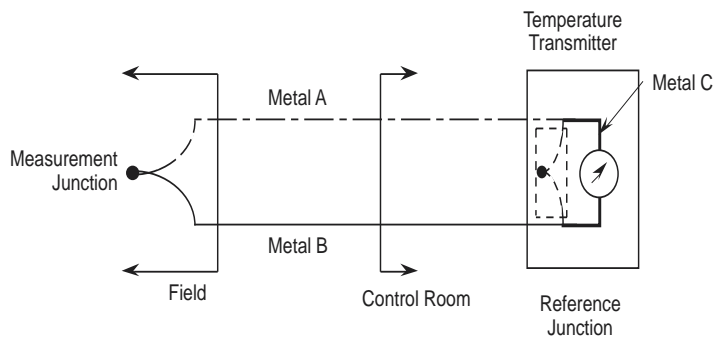
Note



**Figure 4**  
**A Simplified Thermocouple Temperature Transmitter**

In Figure 4 above, the temperature measurement circuit consists of a thermocouple connected directly to the temperature transmitter. The hot and cold junctions can be located wherever required to measure the temperature difference between the two junctions.

In most situations, we need monitor the temperature rise of equipment to ensure the safe operation. Temperature rise of a device is the operating temperature using ambient or room temperature as a reference. To accomplish this the hot junction is located in or on the device and the cold junction at the meter or transmitter as illustrated in figure 5.



**Figure 5**  
**Typical Thermocouple Circuit**

### Thermocouple Advantages and Disadvantages

#### Advantages:

- Thermocouples are used on most transformers. The hot junction is inside the transformer oil and the cold junction at the meter mounted on the outside. With this simple and rugged installation, the meter directly reads the temperature rise of oil above the ambient temperature of the location.
- In general, thermocouples are used exclusively around the turbine hall because of their rugged construction and low cost.
- A thermocouple is capable of measuring a wider temperature range than an RTD.

### Disadvantages:

- If the thermocouple is located some distance away from the measuring device, expensive extension grade thermocouple wires or compensating cables have to be used.
- Thermocouples are not used in areas where high radiation fields are present (for example, in the reactor vault). Radioactive radiation (e.g., Beta radiation from neutron activation), will induce a voltage in the thermocouple wires. Since the signal from thermocouple is also a voltage, the induced voltage will cause an error in the temperature transmitter output.
- Thermocouples are slower in response than RTDs
- If the control logic is remotely located and temperature transmitters (milli-volt to milli- amp transducers) are used, a power supply failure will of course cause faulty readings.

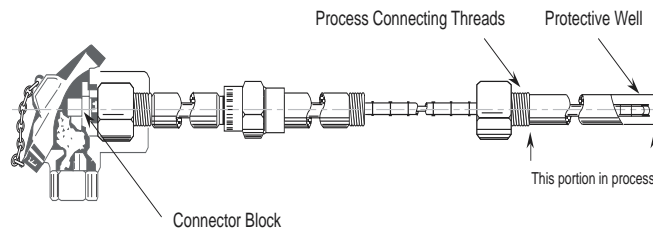
### Failure Modes:

An open circuit in the thermocouple detector means that there is no path for current flow, thus it will cause a low (off-scale) temperature reading.

A short circuit in the thermocouple detector will also cause a low temperature reading because it creates a leakage current path to the ground and a smaller measured voltage.

### 2.4.3 Thermal Wells

The process environment where temperature monitoring is required, is often not only hot, but also pressurized and possibly chemically corrosive or radioactive. To facilitate removal of the temperature sensors (RTD and TC), for examination or replacement and to provide mechanical protection, the sensors are usually mounted inside thermal wells (Figure 6).

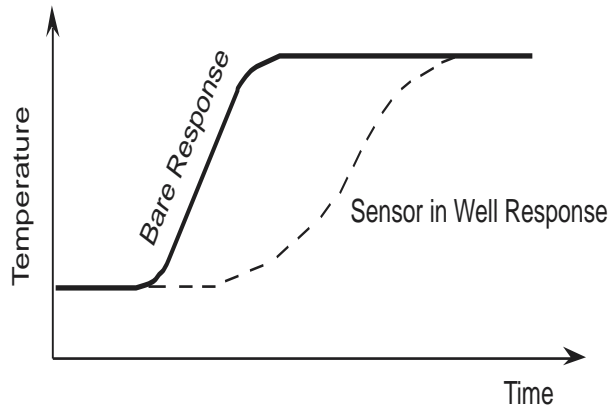


**Figure 6**  
**Typical Thermal Well Installation**

A thermal well is basically a hollow metal tube with one end sealed. It is usually mounted permanently in the pipe work. The sensor is inserted into it and makes contact with the sealed end.

A drawback to thermal wells is their long response time because heat must be transferred through the well to the sensor. An example of the temperature response for bare and thermal well installed sensors is shown in Figure 7. Minimizing the air space between the sensor and the well, however, can decrease this thermal lag.

Note



**Figure 7**  
**Response Curves of Bare and Thermal Well Installation**

#### 2.4.4 Thermostats

Thermostats have a different function than the resistive temperature detectors and thermocouples that we have just discussed. The thermostats directly regulate the temperature of a system by maintaining it constant or varying it over a specific range. The T/C or RTD could be used as the temperature-sensing element of a thermostat, but generally thermostats are direct acting devices.

The two common types of thermostats are:

Pressure cylinder

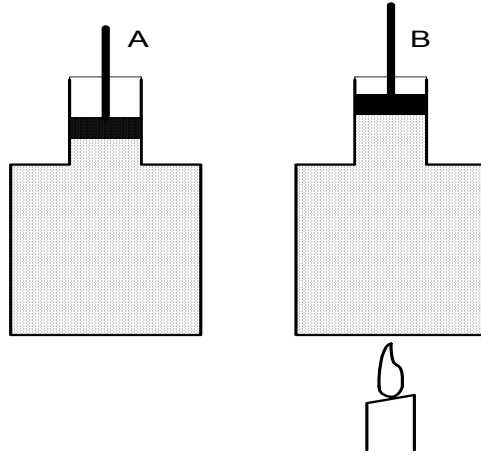
Bimetallic strip



## Pressure Cylinders

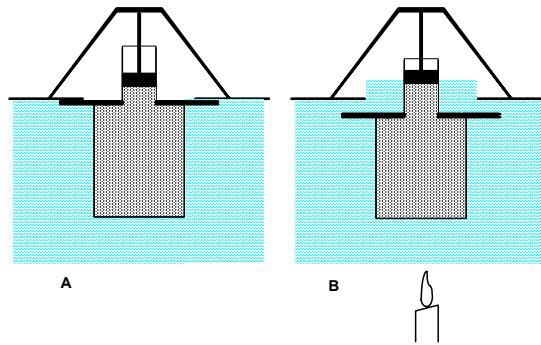
The most common thermostat depends on the expansion of a fluid such as mercury or a solid with an increase in temperature as in figure 8.

Note



**Figure 8**  
**Thermostat Pressure Cylinder**

The plunger connected to the piston is used to force contacts open and closed to control valve positions or pump control. Often the plunger is directly connected to the valve as in figure 9 below. This is the same principle as used in automobile water thermostats where the substance in the cylinder is a wax with a melting point of around 180<sup>0</sup> F.

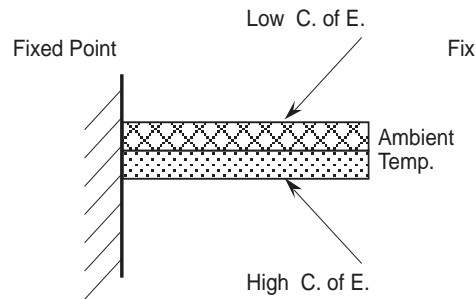


**Figure 9**  
**Thermostat Pressure Cylinder Application**

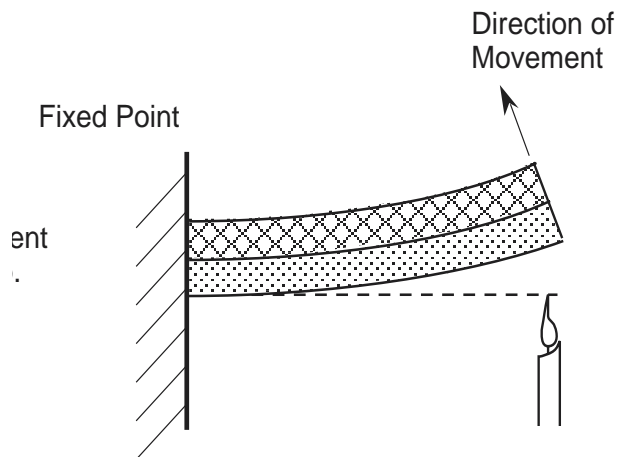
## Bimetallic Strips

A bimetallic strip is constructed by bonding two metals with different coefficients of thermal expansion (Figure 10). If heat is applied to one end of the strip, the metal with the higher coefficient of expansion will expand more readily than the lower one. As a result, the whole metallic strip will bend in the direction of the metal with the lower coefficient (Figure 11).

Note

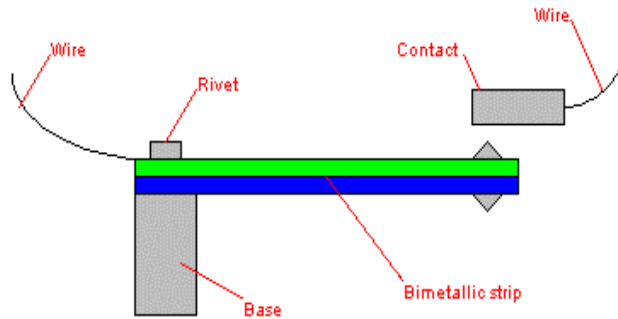


**Figure 10**  
**A Bimetallic Strip**



**Figure 11**  
**Bimetallic Strip Bent after Heat is Applied**

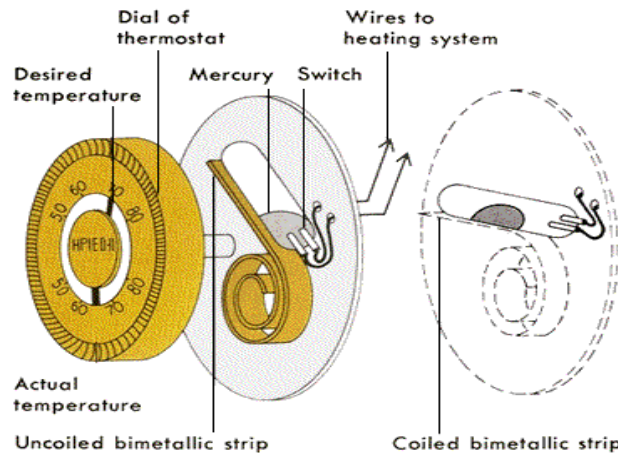
When contacts are attached to the strip, it can be used as a fast acting thermostat to control air temperature as per figure 12. One drawback is that there cannot be any flammable vapours surrounding the strip due to arcing generated across the contacts.



Note

**Figure 12**  
**Bimetallic Thermostat**

One main advantage of the bimetallic strip is that it can be used to operate over a range of temperatures when the strip is fashioned into a coil (for larger swing) and placed on an adjustable pivot (figure 13). Most room thermostats operate on this principle.

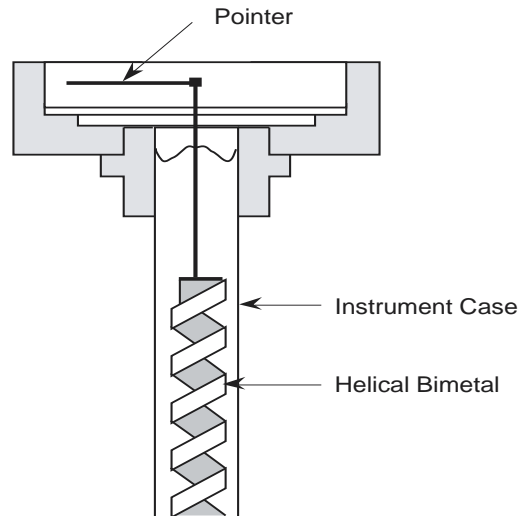


**Figure 13**  
**Application of Bimetallic Strip**

### Bimetallic Thermometers

Another common configuration of the bimetallic strip is coiled in a helix to increase the swing or displacement similar to the coil above. In this shape, the strip is more rugged and less subject to vibration. A helical bimetallic thermometer is shown in Figure 14 below.

Bimetallic thermometers in general are very rugged and require little maintenance. They are usually used to measure process parameters such as pump and bearing temperature.



Note

**Figure 14**  
**Helical Bimetallic Thermometer**

## 2.5 NEUTRON FLUX MEASUREMENT

A CANDU reactor generates thermal power from heat produced by nuclear fission. However, measuring the actual thermal power output proves to be too slow for the purpose of controlling the reactor (there is a time lag of about 25 seconds between neutron flux change and thermal output measurement). To control the reactor adequately, it is necessary to have fast responding instrumentation. The method of measuring reactor power by observing the radiation directly associated with the fission process is used. Each time a fission occurs; radiation (neutron, beta, gamma or alpha) is produced. The magnitude of these radiations is directly proportional to the number of fissions, which is in turn directly related to the reactor power level. The radiation we choose to monitor is neutron flux. If we can measure the neutron flux, we can estimate the thermal output of the reactor. In addition, monitoring neutron flux acts as a safeguard against the possibility of losing control of the reactor. If neutron flux exceeds a predetermined limit, shutdown systems will be triggered by the sensed neutron signal.

### 2.5.1 Neutron Flux Detection

Power produced by thermal nuclear reactors is generated through fission induced by slow neutrons. Hence, nuclear sensors that are part of the reactor control or safety systems are generally based on detectors that respond primarily to slow neutrons. The control of a reactor is necessary over a wide range of neutron flux levels from zero to full reactor power at  $10^{14}$  n/(cm<sup>2</sup> s). The level of  $10^7$  n/(cm<sup>2</sup> s) is approximately zero thermal power for all practical purposes and significant thermal power contribution does not occur until the flux rises to  $\sim 10^{12}$  (1% FP). The normal operating range of the reactor is usually between  $10^{13}$  and  $10^{14}$  n/(cm<sup>2</sup> s).

It is more convenient to describe the flux density in terms of the logarithmic value, with 14 being full power ( $10^{14}$  N/(cm<sup>2</sup> s) = 100%FP). By terminology, the neutron flux is said to have gone through 14 decades from zero to full power.

In order to provide instrumentation that will have complete coverage over this large range and still maintain accuracy, it is necessary to split the detection into three areas of sensitivity.

1. Sub-critical  $\alpha$  0 to  $10^7$  n/(cm<sup>2</sup> s). Neutron detection in this region is covered by two sets of start-up instrumentation:
  - In core BF<sub>3</sub> proportional neutron counters with a range  $10^{-14}$  to  $10^{-10}$  FP.
  - Out of core He-3 proportional neutron counters with a range of  $10^{-11}$  to  $10^{-6}$  FP.
2. Run up  $\alpha$   $10^7$  to  $10^{13}$  n/(cm<sup>2</sup> s). Primary detection by external to core ion chambers. With a range of  $10^{-7}$  to 1.5 FP.
3. Under-load  $\alpha$   $10^{13}$  to  $10^{14}$  n/(cm<sup>2</sup> s). Primary detection by internal core neutron detectors with a range of 0.15 to 1.5 FP.

As there are different detectors used, overlap of the detectors is necessary to provide a smooth transfer of reactor control throughout the three areas and to provide backup instrumentation if the main detectors are in question. We will look at each of these areas in more detail.

### 2.5.2 Neutron Detection Methods

Neutrons, like gamma rays, have no charge and therefore cannot directly interact with instrumentation, as do charged particles and electrons. Neutrons can also travel through many centimeters of matter without any type of interaction and thus can be totally invisible to a detector of common size. When a neutron does interact it is with a nucleus of the absorbing material. This interaction may either cause the neutron to disappear totally and be replaced by one or more secondary radiations or change the energy or direction of the neutron significantly.

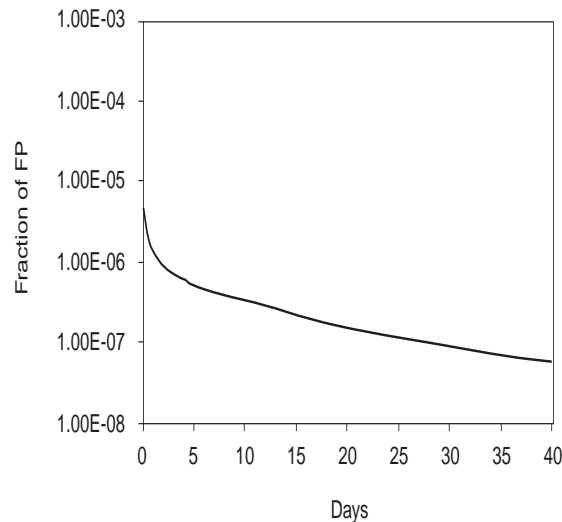
Secondary radiations resulting from neutron interactions are almost always heavy charged particles. These particles may be produced either as a result of neutron-induced nuclear reactions or they may be the nuclei of the absorbing material itself which have gained energy from the neutron collisions.

Most neutron detectors utilize some means of converting the incident neutron into secondary charged particles that can then be detected directly. For slow (thermal) neutrons, which have a small amount of kinetic energy, several different neutron reactions can be used. These include; (1) prompt capture of neutrons resulting in charged particle emission, (2) delayed activation reactions where an activated nucleus emits some form of radiation within a convenient half-life and energy and (3) fission reaction resulting from neutron capture.

### 2.5.3 Start-up (sub-critical) Instrumentation

If the reactor had been operating for some time and the shut-down is short (max. 2-3 weeks), the fission products will have built up to a point where the photo-neutron presence will still be large enough in the reactor to be detected by the run-up instrumentation (ion chambers).

For longer shutdowns, where the power has dropped to a relatively low level, the readings from the ion chambers are unreliable because the background gamma radiation levels heavily influence them. After some time, power will drop to a level where the installed instruments go off-scale (below about  $10^{-7}$  FP) and the regulating system will not automatically control the power. Figure 1 shows a typical power decay curve for a CANDU reactor. It can be seen that after about 3 weeks supplementary proportional counters are necessary to maintain a reliable power record. Moreover, a subsequent approach to critical would need to be done using the proportional counters in the initial stages.



**Figure 1**  
**Power Decrease Following Shutdown**

Note

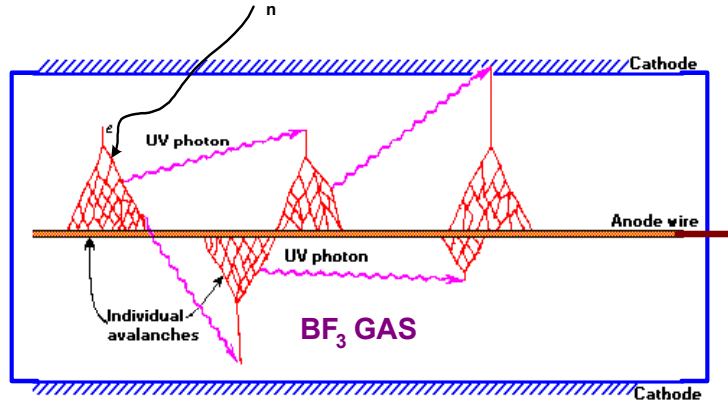
The start-up instrumentation is comprised of two separate portable neutron detection systems, one for in-core and the other for out-of-core. These systems have two decades of overlap.

The out-of-core detectors consist of He-3 filled proportional neutron counters that can be located in the ion chamber shutter holes. As we have indicated this instrumentation measures power from  $10^{-11}$  to  $10^{-6}$  FP.

The BF<sub>3</sub> (boron tri-fluoride) in-core detectors consist of boron in fluoride-filled proportional neutron counters that can be installed in the in-core detector holes. This instrumentation measures the range from  $10^{-14}$  to  $10^{-10}$  FP and is used for start-up with fresh fuel. The energy released per reaction is higher in B-10 than He-3, which enables the BF<sub>3</sub> counters to better discriminate against background gamma pulses.

The BF<sub>3</sub> proportional counter (Figure 2) is a self-amplifying device that uses the ions originally produced to make other ions in the same region. Inside the proportional counter is an electrode of fine wire along the axis of the second electrode that is a hollow cylinder. The effect of the wire is to give strong electric field strengths close to it. This strong field quickly accelerates the primary ions to gain enough energy in the acceleration to produce secondary ionization pairs. These newly formed secondary ions are also accelerated causing additional ionizations. The large number of events, known as a Townsend avalanche, creates a single, large electrical pulse.

Since a single pulse is produced for each incident radiation particle or photon, it is easy to directly measure the number of incident neutrons, which interacted with the detector.



Note

**Figure 2**  
**BF<sub>3</sub> Proportional Counter**

BF<sub>3</sub> (boron tri-fluoride) gases used in proportional counters are enriched to about 96% in B-10, which results in a level of efficiency five times greater than the natural boron gas. BF<sub>3</sub> tubes can readily discriminate against gamma rays that are often found with the neutron flux being measured. Gamma rays interact primarily in the wall of the counter and create secondary electrons that may produce ionization in the gas. Because the stopping power for electrons in BF<sub>3</sub> is quite low, a typical electron will only deposit a small fraction of its initial energy in the gas (little subsequent ion-pair production) before reaching the opposite wall of the counter. Most gamma ray interaction should result in low-amplitude pulses that can simply be eliminated by an electronic amplitude discrimination circuit without sacrificing detection efficiency.

These sensitive supplementary counters are removed once the standard ion chambers take control. This prevents burnout of the instrumentation by excessive neutron flux during normal reactor operation. The burnout is caused by the rapid burn-up of the high cross section emitter material used to obtain maximum sensitivity.

Due to the fast response time of the BF<sub>3</sub> counters, the outputs are deliberately damped at low flux levels to prevent spurious trips from the shutdown systems.

#### **2.5.4 Fission neutron detectors**

The detectors that use the fission reaction to detect neutrons are called fission chambers. These small ion chambers are typically made of stainless steel walls and electrodes, with an operating voltage from 50V to 300V.



The chamber walls are usually lined with highly enriched uranium to enhance the ionization current.

Argon is the common choice for the chamber fill gas and it is used at a pressure of several atmospheres. The elevated pressure ensures that the range of fission fragments within the gas does not exceed the detector's small dimension. The pulses produced by fission fragments entering the sensitive volume of the detector are large and because the ion chamber does not produce large current flows, the output from the fission chamber is a series of pulses that can be counted.

When the detector is operating, the fissionable material on the detector walls is being consumed (by fission). To help slow the rate of depletion, a fast neutron absorber such as  $^{238}\text{U}$  is sometimes added to the fissionable material on the wall. When  $^{238}\text{U}$  absorbs a fast neutron,  $^{239}\text{Pu}$  is created after beta emission. The  $^{239}\text{Pu}$  is itself a fissionable material.

Miniaturized fission chambers can be tailored for in-core use over any power range likely to be encountered in reactor operation. These detectors can be used as traveling detectors and as a reference point to calibrate self-powered detectors.

### 2.5.5 Ion chamber neutron detectors

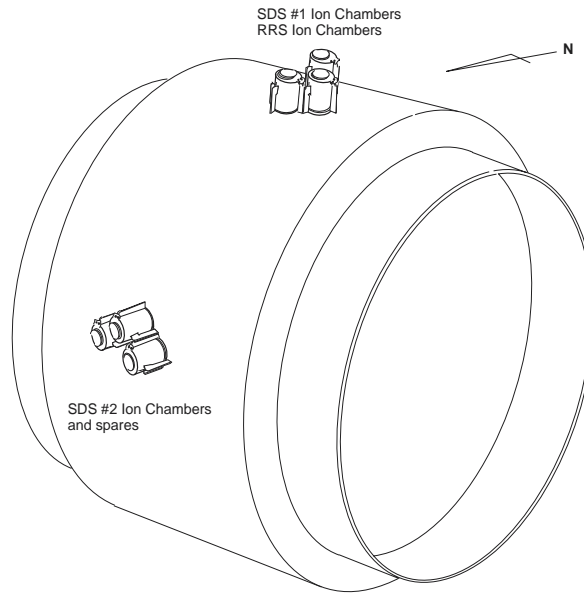
An ion chamber (see schematic in Figure 3) measures the electric charge of ions generated from the interaction of neutrons and the chamber structure and are located on the outside of the reactor core. The output of an ion chamber is a flow of current directly proportional to the incident neutron rate.

under irradiation. It can either be nitrogen-helium or hydrogen. The housing and central electrode is usually pure aluminum because of its low residual activity as a result of neutron bombardment.

Note

Since neutrons are uncharged, the lining of the chamber must be a coating of material, which will emit charged particles under neutron bombardment. Boron-10 was chosen because its high cross-section for the (n,  $\alpha$ ) reaction with thermal neutrons gives high sensitivity. This is important because ion chambers are mounted outside the reactor core where the number of neutrons is limited. Figure 4 indicates a representative location of the ion chambers, although the positioning can vary.

Note

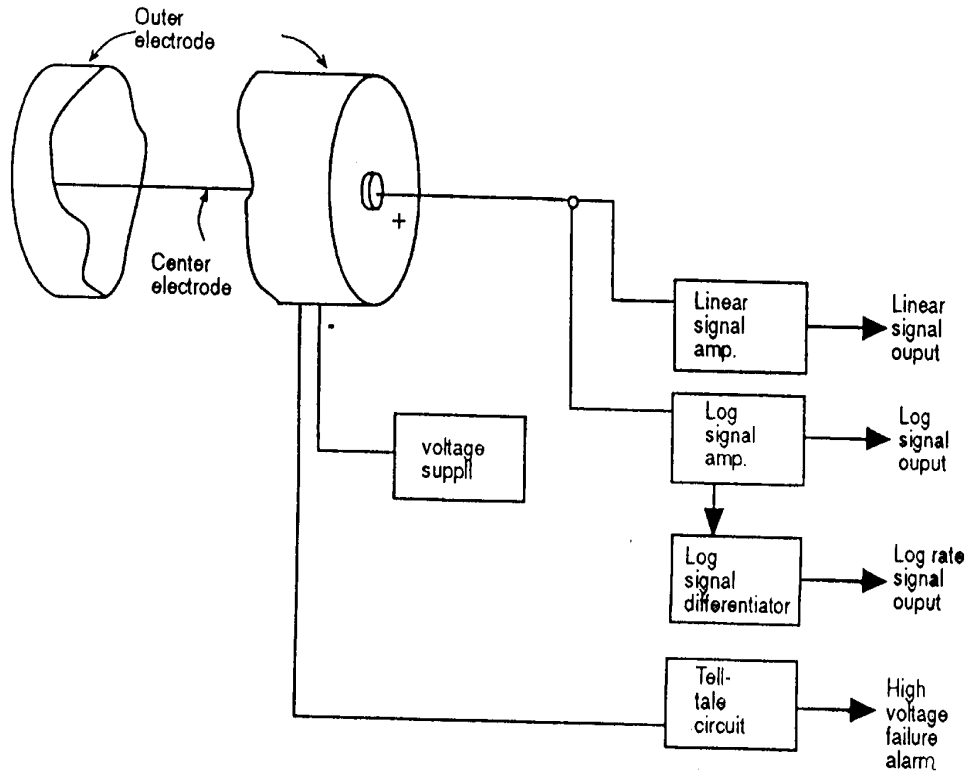


**Figure 4**  
**Typical Ion Chamber Locations**

### **Ion Chamber Operation**

The metal used for the electrode and outside casing is usually pure aluminum because of its low residual activity as a result of neutron bombardment. A high polarizing voltage (typically +600 V) is applied to the aluminum housing, while the center electrode is normally kept at ground potential (see Figure 3).

In the ion chamber, neutrons bombard the boron lining and release positively charged alpha ( $\alpha$ ) particles. When a rapidly moving alpha particle collides with a gas atom it ejects an electron from the atom leaving behind a positively charged ion. This renders the gas conductive with so-called ion pairs that are attracted to the charged electrodes by the polarizing voltage. This creates a flow of electric current, which can be detected by an external circuit. Amplifiers produce three separate signals as illustrated in Figure 5 then process the current signal:



Note

**Figure 5**  
**Ion Chamber Neutron Detector System**

- A signal proportional to the linear power,  $\ln n = 0$  to 150% FP
- A signal proportional to the logarithm of the power,  $\text{Log } n = -0.7$  to 0 decades
- A signal proportional to the rate of change of the logarithm of power,  $\text{log } n \text{ rate} = -15$  to  $+15\%/sec$

At low reactor power level, say below 15% full power, control of bulk reactor power is important. Ion chambers, because of their fast response time and high sensitivity are used for low power neutron flux detection. Ion chambers are used for the Reactor Regulating System (RRS) and Shut Down Systems (SDS) because of their fast response time.

### **Gamma Discrimination for Neutron Ion Chambers**

One of the problems with the ion chamber is that the detector is indiscriminate and is affected by other ionizing radiation especially gamma. (The external alpha and most beta radiation cannot penetrate the housing.)

Note

Gamma rays will produce high-energy electrons (termed photo-compton electrons) and subsequent ionization. Therefore it is important to ensure both at power and after shutdown, when fission gamma radiation is predominant, that gamma radiation does not give a false (high) indication of reactor power.

Discrimination against gamma rays is achieved by:

- Employing appropriate materials in the detector and by gamma shielding (lead) in the construction of the ion chamber housings. With shielding the neutron to gamma current ratio is kept at about 1000 to 1 at high power level.
- Keeping the active part of the ion chamber relatively small.

### **Factors Affecting Ion Chamber Detector Accuracy**

Proper functioning of ion chamber systems is essential to avoid unnecessary shutdowns, especially at low power when the in-core flux detector system is not capable of providing accurate data and therefore is not used.

A lower or negative signal can be caused by either the reactor power being off scale (that is, less than  $10^{-5}\%$  FP) or a failure in the system. The other two channels will determine whether the power is off scale

A lower or off-scale reading can be caused by any of the following::

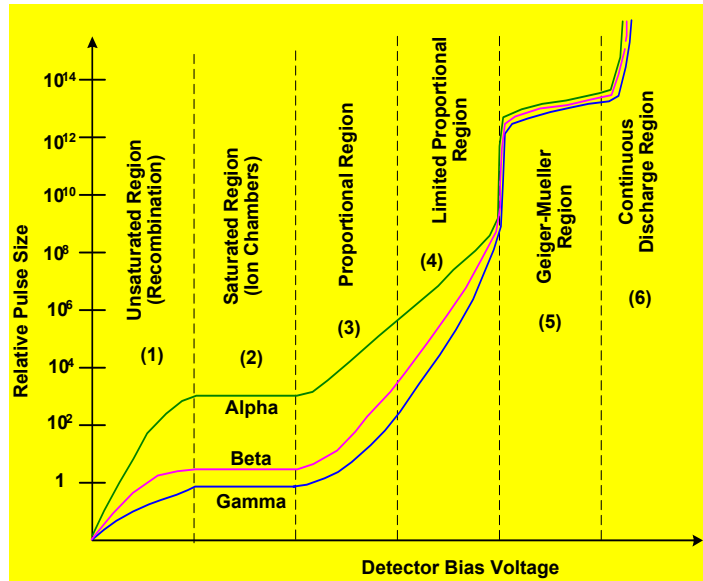
- Low moderator level. If the moderator level drops, the neutron velocity in the uncovered area will increase and will be too fast to allow displacement of the alpha particles by the Boron emitters of the ion chambers. The output of the ion chamber will indicate a lower neutron flux reading.
- Loss of HV power supply for the ion chamber polarization voltage.
- Shutdown of the Reactor. At less than  $10^{-5}\%$  FP the output will be zero or irrational. Normal nuclear instruments (ion chambers and/or flux detectors) will be off-scale at their low end ( $\sim 10^{-5}\%$  of full power) and so the regulating system will not automatically control the reactor.

## Effect of Voltage on the Ionization Detector Process

Ionization detectors as previously discussed are a versatile instrument for detection of radiation.

These gas filled chambers can be operated as ion chambers, proportional counters, or Geiger-Mueller (GM) tubes depending on the bias voltage applied to the detector. Figure 7 illustrates the gas amplification curve (also called the six-region curve) for gas filled detectors. It is a curve of the relative electrical pulse size created at the collector compared to the voltage between the emitter and collector.

Note



**Figure 7**  
**Six-Region Curve for Gas Filled Detectors**

You will notice from the curve that at low voltages a high percentage of the ions recombine before reaching the collector. This region is not usable for detection purposes. As the bias voltage is increased into the ion chamber region, a point is reached at which essentially all of the ions are collected before they can recombine. No secondary ionization or gas amplification occurs. At this point the output current will be proportional to the radiation intensity and relatively independent of fluctuations in the power supply.

As the bias voltage is increased beyond the ion chamber region into the proportional region, the ions created by primary ionization are accelerated by the electric field towards the electrode. Unlike the ion chamber region, however, the primary ions gain enough energy in the acceleration to produce secondary ionization pairs. These newly formed secondary ions are also accelerated, causing additional ionizations.

The large number of events, known as an avalanche, creates a single electrical pulse. In the proportional region, the detector output is proportional to the total ionization product in the detector.

The ratio between the primary ionizations and the total number of ion pairs produced is known as the gas amplification factor for that gas and can be in the order of one million, compared to the gas amplification factor of one for the ion chamber region.

As the bias voltage is increased beyond the proportional region, the detector enters the limited proportional region and is unusable for detection purposes. In this region, unpredictable avalanches can interfere with the overall signal.

As the bias voltage is increased even further into the Geiger-Mueller region, the secondary ions are also accelerated to very high velocities and gain sufficient energy to cause ionization themselves. The resulting avalanche caused by a single ionization, results in a single very large pulse. The avalanche continues until the large electrical field created by the ionization interferes with the detector voltage field, decreasing the acceleration of the ions and thus halting the avalanche.

At even higher voltages, the avalanche process cannot be halted, making this region unsuitable for detection purposes.

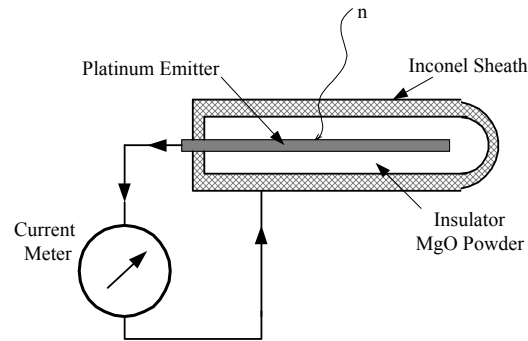
### **2.5.6 In-Core Neutron Detectors**

Although ion chambers are very accurate neutron detectors, their relatively large size and delicate construction make them impractical to be used to detect flux distribution inside the reactor. For this purpose, simple and relatively inexpensive in-core detectors (ICD) have been developed. They are also known as Hilborn detectors, self-powered neutron (SPN) detectors or in-core flux detectors (ICFD).

The advantages of self-powered detectors when compared to other neutron sensors include size, low cost and the relatively simple electronics required to use them. Disadvantages stem from the low level of output current produced by the devices, a relatively high sensitivity of the output current to changes in the neutron energy spectrum and for many types, for instance vanadium detectors, a rather slow response time.

The basic construction of an In-Core Detector (ICD) is shown in Figure 7 with a platinum emitter, although other types of emitter materials can be used.

Note



**Figure 7**  
**Simplified In-Core Detector**

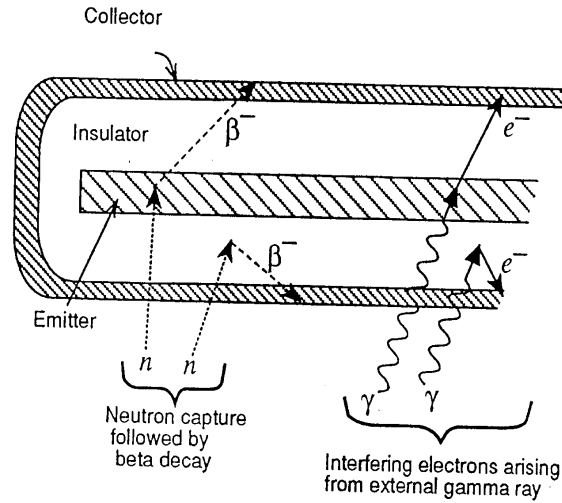
The detector operates by generating an electric current after the central emitter has captured the neutrons. This current is proportional to the rate at which neutrons are captured in the detector. The detector itself resembles a coaxial cable usually about a meter in length and consists of an outer inconel (an alloy of nickel, chromium and iron) sheath and an inner emitter wire, separated by a layer of insulation (usually magnesium oxide, MgO). Magnesium oxide is most commonly used as it can withstand the extreme temperature and radiation environment in the reactor core.

In-core detectors are usually denoted by the material of their emitters, which in CANDU reactors are made of vanadium, platinum, platinum clad inconel (inconel 600 core wire with a thin surface layer of platinum) and inconel.

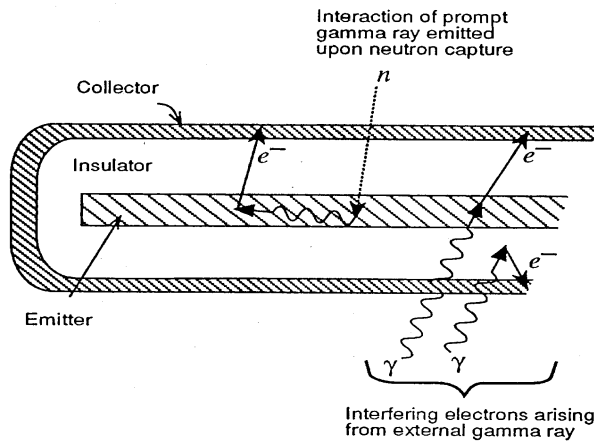
Operation of these detectors requires no external power supply and that is why they are called self-powered. The operation [see Figures 8(a) and 8(b)] is quite simple. The current that corresponds to the beta rays given off by the emitter is measured between the emitter and the outer shell, called the collector.



Note



**Figure 8(a)**  
**In-Core Detector Operation (a)**



**Figure 8(b)**  
**In-Core Detector Operation (b)**

Incident radiation (through the mechanisms described below) will cause electrons to be emitted mostly from the emitter. The emitter is then positively charged with respect to collector. The collected electrons pass through the external amplifier and back to the emitter producing a useful signal.

The 3 principal components of the generated current and main interactions are as follows:

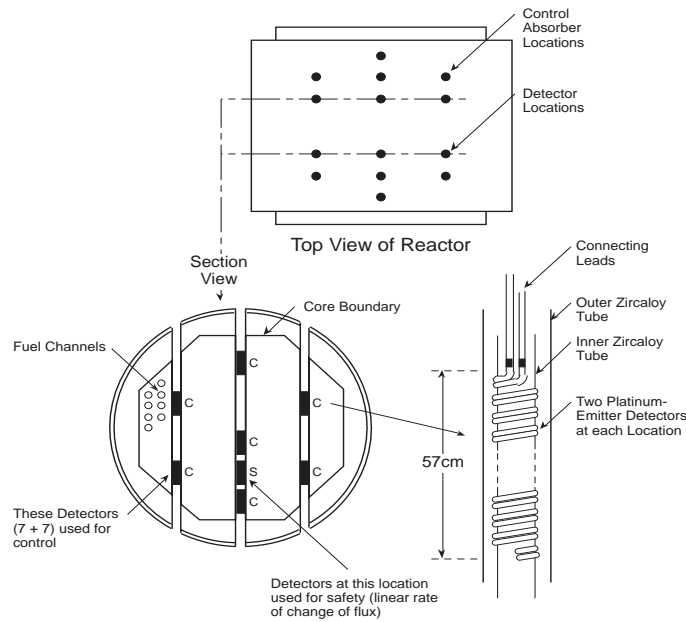
- $(n, \beta)$  mechanism that is, beta emission [Figure 8(a)] following neutron capture mostly by the emitter (neutron activation). This beta decay current is proportional to the rate at which neutrons are captured in the detector but has a rather slow response time.
- $(n, \gamma)$  followed by the emission of a Compton or photo electron, in which electrons are produced by neutron capture gamma rays [Figure 8(b)] mostly from the emitter. The radioactive capture gamma rays are emitted within a very small fraction of a second following neutron absorption.
- Photo and Compton electrons are produced by gamma ray sources external to the detector. These gammas will either be directly from fission or from the decay of fission products (Figure 8).

External electrons and beta particles from the reactor hardware and materials can also contribute to the detector signal, but this 4th mechanism usually does not add more than a couple of per cent to the overall output current.

In-core detectors can be either coiled (on an inner zircaloy tube) as shown in Figure 9 or Straight Individually Replaceable (SIR) in a flux monitor assembly. (ICD assemblies could be of various types, i.e., wet, encapsulated and HESIR or hybrid encapsulated straight individually replaceable and positioned either vertically or horizontally in the reactor core.)

Note

Note



**Figure 9**  
**Typical ICD Locations**

### Types of In-Core Detectors

The time relationship between a device input and output is called its dynamic response. Following a step change in reactor neutron flux the current produced by each isotope in the ICD material through each of the three basic interactions can be either a prompt (immediate) response or a delayed one. Delayed responses are usually described by exponential lag terms with time constants characteristic for the isotope and mechanism. The total response of the ICD is a sum of prompt and delayed (or lag) terms.

For a change in neutron flux in the core, the three reactions exhibit different response characteristic with respect to time.

The first (a) interaction discussed previously ( $n, \beta$ ) will normally be delayed following a change of neutron flux. The return to a new steady state condition will be dependent upon the materials used.

Interactions (b) and (c) are prompt reactions with respect to the neutron and gamma fluxes, respectively. Note again, however, that following a change in fission rate a portion of the gamma signal source (due to the presence of fission products and activation products) will exhibit a delay time before it reaches a new steady state condition. In other words, the gamma flux at the detector site has its own dynamic response (lag terms) relative to neutron flux. Thus, although the Compton and photoelectric mechanisms are prompt with respect to gamma, the current generated by it, following a change in neutron flux, will have a prompt component from prompt gammas and a delayed part from gamma rays emitted by fission products and activation

products. Those products need time to reach a new equilibrium state after a neutron flux change.

The sensitivity of the detector, that is the amount of current output per detector unit length and per unit neutron flux, changes with exposure to neutron flux and is known as burn-up. There are two main reasons for this: the current producing isotopes in the detector burn up by neutron capture and beta decay and the flux environment of the detector changes.

The sensitivity of in-core detectors to the three interactions and their dynamic response depends on the material of the emitter.

### **Platinum and Platinum Clad Detectors**

The response of platinum detectors with respect to the 3 mechanisms is as follows:

- Output due to Beta decay following neutron activation of the platinum emitter is up to about 3%
- Input due to Compton and photo-electrons produced by neutron capture gamma rays ( $n, \gamma$ ) from the emitter is around 60%.
- Output due to Compton and photo-electrons produced by external gamma sources is around 40%.

Output (a) is delayed with a half-life of 30 minutes, i.e., a typical time to stabilization of this component following a neutron flux change would be 150 minutes (5 half-lives).

The dynamic response of the ICD signal shows small changes with exposure to neutron radiation. For Pt and Pt-clad detectors the percentage declines with neutron exposure time from about 90% in the beginning to about 80% after very long (~ 20 years) neutron exposure.

Note that this type of ICD detects both neutron and gamma rays resulting from the fission reaction. This feature has several advantages:

- Prompt response.
- Less neutron loading on reactor (low capture cross section).
- Less temperature dependence.
- Less susceptible to local flux perturbations.
- Little change in sensitivity with respect to time.

Note

### **Inconel Detectors**

For ICD detectors with inconel emitters the contribution of direct Compton and photoelectric mechanisms are usually estimated at less than 10%. Practically all the signal current comes from the  $(n, \gamma)$  followed by a Compton or photoelectric electron interaction, with zero from the  $(n, \beta)$  mechanism. The interesting aspect of the inconel detector dynamic response is that it is over prompt or to put it differently, its delayed component is negative. Thus, following a step change in neutron flux in the core the inconel detector responds right away with about 101-104% of the equilibrium signal. (The three main delayed components of the signal have time constants equal to 95 sec, 25.6 min. and 3.7 hrs.) Inconel detectors are used at Darlington (RRS and SDS1) and at Bruce B (SDS1).

### **Vanadium Detectors**

We will mention the last category Vanadium detectors for reference only. They have been used for flux-mapping of the core but are seldom used at the present. Vanadium detectors are used for applications where speed of response is not as important as accuracy of neutron flux value. For this a detector, which is only neutron sensitive, is required. This feature is necessary when mapping the three-dimensional flux shape throughout the reactor. Vanadium detectors are essentially 100% neutron sensitive, i.e., the  $(n, \beta)$  mechanism contributes nearly 100% to the signal. The response is dependent upon the emission of beta particles from the emitter following neutron activation. The response is delayed following a change in neutron flux levels.

### **Factors Affecting in Core Detector Measurement**

1. Fuelling or reactivity device movements nearby.

Platinum ICD signals, although very fast, do not reliably indicate average power in the zone because they only sample the flux in their region. They are therefore susceptible to localized flux changes such as refuelling or reactivity mechanism movement.

2. Start-up of the reactor.

At start-up, there is not enough neutron flux and the neutron interaction rate is very low. Good discrimination against gamma rays is essential in this range and it can be accomplished by using either fission chambers or BF<sub>3</sub> proportional counters. Also, Platinum ICDs have delayed components, approximately 15% to 17% of the total signal lags power change by a time constant varying from a few

seconds to hours.

So the signal produced by the detector during a power change may not accurately represent the true fuel power

Note

### 3. Long-term exposure to neutron flux.

ICD's suffer burn up under irradiation. However, with the use of platinum detectors, this is a relatively minor factor being limited to approximately 1% per year.

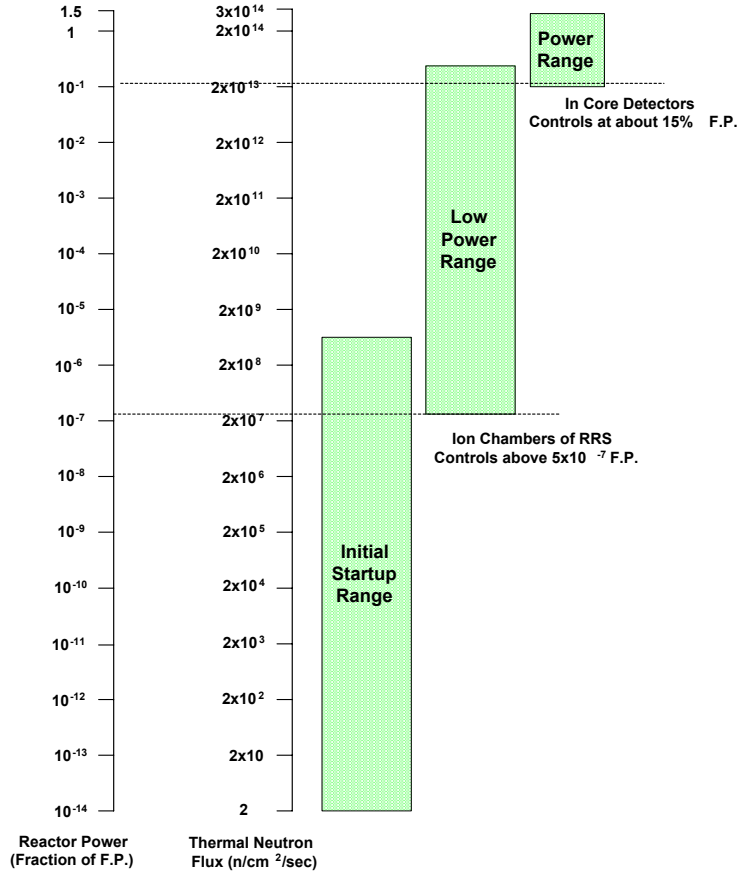
### 4. Moderator poison (shielding).

In the event of poison addition to the moderator, for example to provide an equivalent xenon load on start-up, the signal output will be reduced due to the presence of the neutron absorbing poison between the detector and the neutron source (fuel).

## 2.5.7 Reactor Control at High Power

At the higher end of the power range the ion chambers are not sufficient for power control. Although the ion chamber and the linear amplifier are accurate from 10<sup>-5</sup>% to 150% full power (FP), the leakage flux they monitor is not a good representation of the flux in the reactor core for the simple reason that these detectors are installed outside the reactor. The leakage flux will be strongly affected by moderator poison, fueling in adjacent channels, flux tilts, movements of nearby reactivity devices, etc., and it will be relatively insensitive to power changes in the central core or the far side of the reactor.

This is particularly important in the last decade for the following reason: above about 20% - 25% FP CANDU reactors require spatial (also called tilt) control capabilities in addition to the overall or bulk control function. This is needed in order to remove neutron flux tilts caused by local reactivity changes (due to fuelling or movements of some reactivity devices) and to prevent xenon oscillations. To provide spatial control, the Reactor Regulating System (RRS) needs neutron sensors distributed throughout the reactor. Ion chambers are too big and too fragile to be put inside the reactor core. Thus in the last power decade, the RRS switches from ion chambers to in-core detectors for measuring and controlling bulk and spatial power. However, in-core detectors can generate a reliable signal only from about 1% to 120% full power. Below 1% FP, the in-core detector signal is not distinguishable from noise. Therefore, below about 10% FP ion chambers have to be used to keep the reactor under the RRS control.

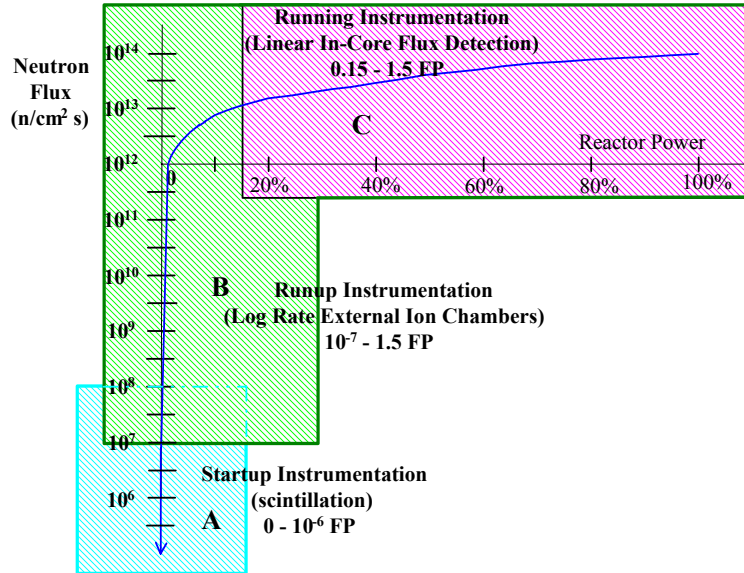


Note

**Figure 10(a)**  
**Neutron Detector Over-Lap**

### 2.5.8 Overlap of Neutron Detection

At various stages in the CANDU reactor operation, the proportional counters, uncompensated ion chambers and self-powered in-core flux detectors are used to give a measurement of reactor power from source level to 150% full power. A minimum overlap of one decade is provided between successive ranges of instrumentation as schematically portrayed two different ways; a bar graph Figure 10(a) and neutron flux vs. reactor power Figure 10(b). The overlap of instrumentation maintains continuity of measurement between the ranges of sensitivity.



Note

**Figure 10(b)**  
**Neutron Detector Over-Lap**

Notice again that the ion chambers generate a current signal proportional to the reactor power level over seven decades of flux. The in core detectors, as mentioned previously, generate a current signal over the final two decades of flux, but are used only in the last decade.

There are several means of transferring reactor control (RRS) between the over-lapped instrumentation:

The transfer between log and linear control in some locations is done at 17% FP on rising power, as measured by the ion chambers and at 13% FP on falling power, as measured by the ICD's. This 4% hysteresis prevents cycling between log and linear control and also allows for slight differences in calibration due to the different types of detector used.

Another similar method employs a 13% - 17% hysteresis, but linear power (ICD signal) is used for switchovers (in both ways) between log and linear control to ensure a bump-less transfer.

A different method that can be used requires the ion chambers to be thermally calibrated. The transfer is implemented between 5% and 15% FP by progressively phasing out the ion chamber signal and phasing in the in-core detector signal as power increases. Again, a bump-less transfer is ensured.

When the RRS transfers from ion chambers to in-core detectors, there is also another associated change, namely the power measuring and indicating scale changes from a logarithmic (log) to a linear one.



The log signal comes from a log signal amplifiers associated with ion chambers as shown in Figure 5.

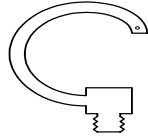
A log scale is useful for measurements spanning several decades because it gives a constant signal change per decade, e.g., 2 volts per decade of neutron power. However, it bunches up (flattens out) at the top of each decade, which is inadequate for the last decade (see Figure 10b) where the most heat is generated and fine control is required. For this reason in-core detectors use a linear scale, which is more intuitive. Because of the scales, we talk about the two RRS bulk control ranges; the logarithmic range from  $10^{-5}\%$  FP to about 15% FP and the linear range of control from about 15% to about 120% FP. Because of the names it is easy to forget that the really important difference is in the neutron sensors used for control and that the scale depends on the associated type of amplifier or a computer algorithm transforming a linear value to a logarithmic one or vice versa.

Note

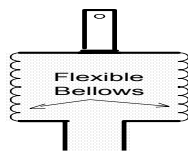
### REVIEW QUESTIONS - EQUIPMENT

1. Briefly explain how each of the following devices is used to measure pressure.

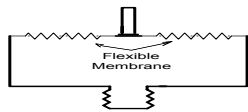
Note



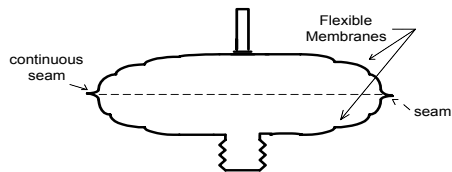
- a. Bourdon Tube



- b. Bellows



- c. Diaphragm



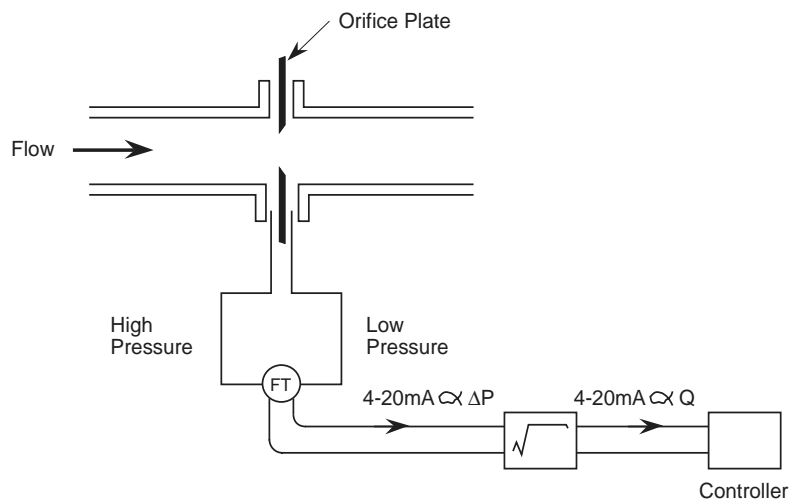
- d. Capsule

2. Explain how the capacitor capsule, differential pressure transmitter detects pressure differences.
  
3. Describe a strain gauge.
  
4. A pressure-measuring instrument is designed around a bourdon tube. Explain how extreme changes in the ambient temperature of the bourdon tube will introduce errors into the readings of the instrument.
  
5. Briefly describe how the ambient pressure in a room containing a pressure transmitter can affect the reading of the transmitter.
  
6. Explain how flow can be measured using an orifice plate, venturi or flow nozzle.
  
7. Explain how elbow taps are used to measure the flow in a steam line.

Note

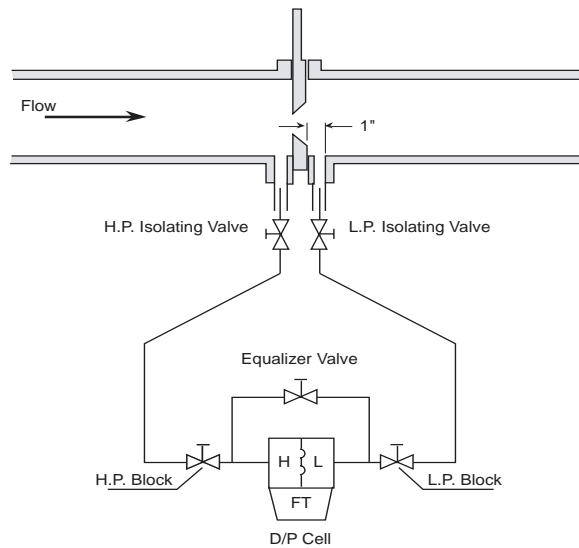
Note

8. Briefly describe the how each of the following devices is used to measure flow.
- a. Orifice plate
  - b. Venturi
  - c. Flow nozzle
  - d. Elbow tap
  - e. Annubar
  - f. Pitot tube
9. For each of the following devices explain how flow measurements will be affected by
- a. Changes in fluid temperature
  - b. Changes in fluid pressure
  - c. Erosion
    - i. Orifice plate
    - ii. Venturi
    - iii. Flow nozzle
    - iv. Elbow tap
10. The drawing below shows a typical flow control loop. Explain the purpose of the square root extractor.

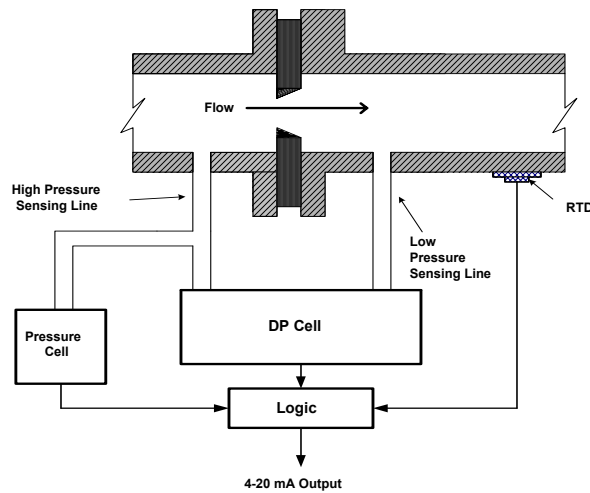


Note

11. A differential pressure transmitter is calibrated to measure the flow of a liquid. Explain what will happen if the fluid is not pure liquid but contains some vapor bubbles.
12. On the following drawing identify the following.
  - a. Three valve manifold
  - b. Primary element
  - c. Transmitter



13. The following diagram shows a density corrected flow loop. Briefly explain the operation of the loop.

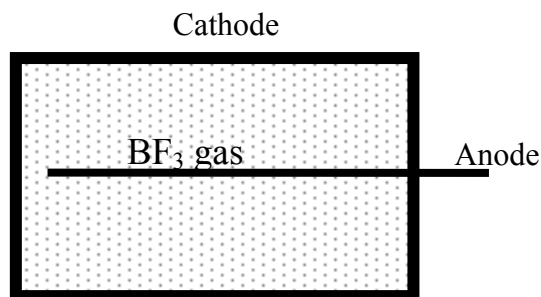


14. In a flow loop using a venturi for a primary element what will be the consequences of the following abnormalities?
  - a. Vapor formation in the throat
  - b. Clogging of the throat by foreign material
  - c. Leaks in the Hi pressure sensing line
  - d. Leaks in the low pressure sensing line
15. Sketch the typical installation of a pressure transmitter on an open tank, measuring the level of the fluid in the tank. Explain how this transmitter derives a level signal.
16. Sketch the typical installation of a dry leg level transmitter installation. Explain how this transmitter derives a level signal.
17. Sketch the typical installation of a wet leg level transmitter installation. Explain how this transmitter derives a level signal.
18. The three-valve manifold on a level transmitter must be operated correctly when either removing the transmitter for service or returning it to service. Explain how the transmitter may be damaged by incorrect operation of the manifold.
19. Zero elevation and zero suppression are calibration techniques used in level transmitter calibrations. Explain the purpose of these techniques.
20. Explain how a bubbler is used to measure the level in an open tank.
21. Explain how a bubbler is used to measure the level in a closed tank.
22. A dry leg level transmitter installation is measuring the level of a hot water tank. What happens to the level and the level indication if the temperature of the tank is increased and no water leaves the system?
23. A dry leg level transmitter installation is measuring the level of a hot water tank. What happens to the level and the level indication if the static pressure on the tank is increased and no water leaves the system?

Note

Note

24. Describe the effects on a level transmitter of the following abnormalities in a wet leg configuration.
  - a. a leak in the high pressure sensing lines
  - b. a leak in the low pressure sensing line
  - c. a completed block low pressure sensing line
25. Explain how an RTD is used to measure temperature. Include in your answer a statement to explain why there are three leads from the temperature transmitter to the RTD.
26. What type of signal does a thermocouple produce?
27. RTDs are used to measure the temperature of the reactor outlet feeders. Thermo couples are used to measure temperatures on the turbine. Explain the reasons for the selection of these devices for their respective applications.
28. State the power ranges each of the following neutron detectors will provide the signal for bulk reactor power control.
  - a. Start-up instrumentation
  - b. Ion Chambers
  - c. In Core Detectors
29. Why is there an overlap of the ranges over which the various neutron detectors are used to control reactor power?
30. Using the following diagram explain how a neutron flux signal is derived in a  $\text{BF}_3$  detector



31. Explain the reason that BF<sub>3</sub> detectors burnout if they are left installed when the reactor is at a high power level.
32. Briefly describe how the following ion chamber develops a signal proportional to flux.

Note



37. Explain how each of the following factors can affect the accuracy of the in-core detector flux measurement
- a. Fueling or reactivity device position
  - b. Start-up of the reactor
  - c. Long term exposure to neutron flux
  - d. Moderator poison
38. State the ranges over which the in core detectors and the ion chambers are used to control reactor power. Explain why each is used over this range.

Note

## CONTROL

Note

### 3.0 INTRODUCTION

Control of the processes in the plant is an essential part of the plant operation. There must be enough water in the boilers to act as a heat sink for the reactor but there must not be water flowing out the top of the boilers towards the turbine. The level of the boiler must be kept within a certain range. The heat transport pressure is another critical parameter that must be controlled. If it is too high the system will burst, if it is too low the water will boil. Either condition impairs the ability of the heat transport system to cool the fuel.

In this section we will look at the very basics of control. We will examine the fundamental control building blocks of proportional, integral and differential and their application to some simple systems.

### 3.1 BASIC CONTROL PRINCIPLES

Consider a typical process control system. For a particular example let us look at an open tank, which supplies a process, say, a pump, at its output. The tank will require a supply to maintain its level (and therefore the pump's positive suction head) at a fixed predetermined point. This predetermined level is referred to as the setpoint (SP) and it is also the controlled quantity of the system.

Clearly whilst the inflow and outflow are in mass balance, the level will remain constant. Any difference in the relative flows will cause the level to vary. How can we effectively control this system to a constant level? We must first identify our variables. Obviously there could be a number of variables in any system, the two in which we are most interested are:

The controlled variable - in our example this will be level.

The manipulated variable – the inflow or outflow from the system.

If we look more closely at our sample system (Figure 1), assuming the level is at the setpoint, the inflow to the system and outflow are balanced. Obviously no control action is required whilst this status quo exists. Control action is only necessary when a difference or error exists between the setpoint and the measured level. Depending on whether this error is a positive or negative quantity, the appropriate control correction will be made in an attempt to restore the process to the setpoint.

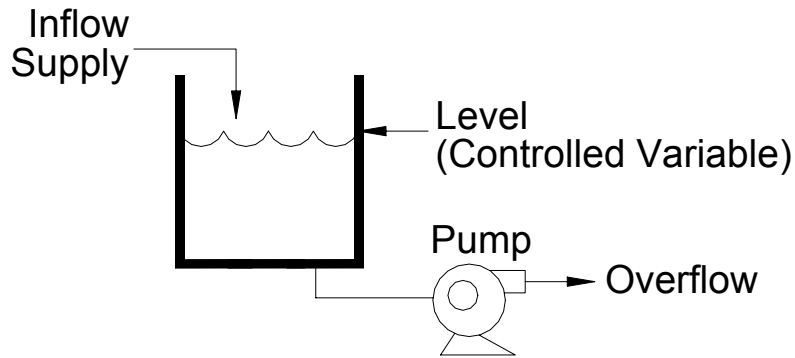
Henceforth, the error will always take the form of:

$$\text{Error} = \text{Setpoint} - \text{Measured Quantity}$$

OR

$$e = \text{SP} - \text{M}$$

Note

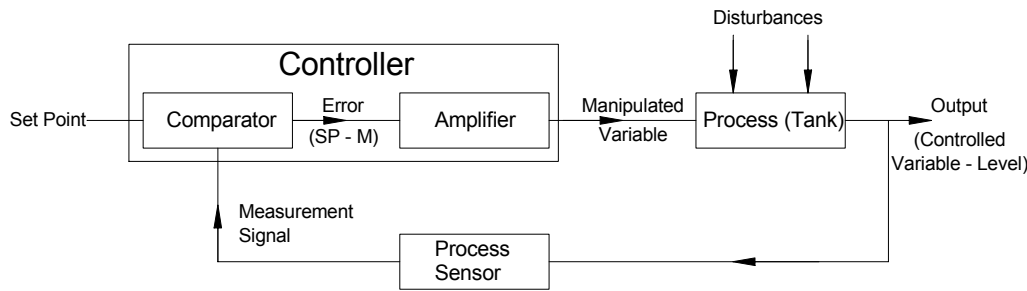


**Figure 1**

The control action will be either to vary the inflow or outflow from the system in order to keep the level at the setpoint. Let us consider the general format for achieving these objectives.

As can be seen from Figure 2, the process can be represented by a closed loop. The system output (level) is monitored by a process sensor and the measurement signal is feedback to a comparator at the input of the system. The second input to the comparator is the setpoint signal; the comparator's output being the difference or error signal. The amplifier, a present just a black box, will provide the appropriate correction to maintain the process at its setpoint despite disturbances that may occur. It can be seen that if the system were being operated in manual control the feedback path would not be present. The operator would provide this feedback and apply the necessary correction to the system whilst observing the effect on the controlled variable. This is termed open loop operation.

Note



**Figure 2**  
**Feedback Control Block Diagram**

### 3.1.1 Feedback Control

This concept justifies the use of the word negative in three ways:

- The negative aspect of feeding the measured signal backwards from the output to the input of the system. (Actual definition of negative feedback control).
- The control correction must be negative in that a correction rather than a compounding of error must occur.
- The fact that an error must occur before a correction can take place, i.e., retrospective or negative control action.

In the next section we will study in more detail the methods used to effect the necessary control corrections.

### 3.1.2 Feedforward Control

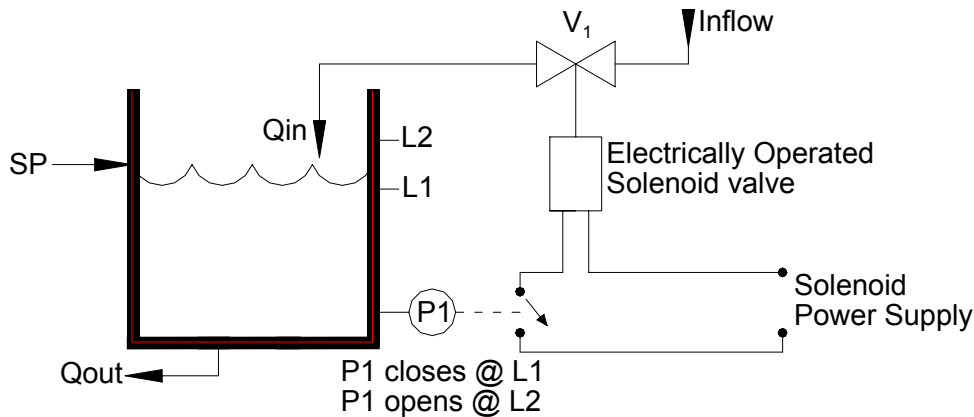
If we wish to control our process without an error first occurring, we must base our control on correction of the disturbances, which will eventually, cause a process error. This is termed feedforward control. Feedforward control is rarely if ever used on its own but is used in conjunction with feedback control to improve the response of control to process disturbances.

### 3.1.3 Summary

Note

- Controlled Variable – output quantity of system (Level, Temperature, etc.).
- Manipulated Variable – means of maintaining controlled variable at the setpoint.
- Error signal – equals the difference between the setpoint and the measurement. ( $e = SP - M$ ).
- Setpoint – desired process level. (SP)
- Measurement – actual process level. (M)
- Closed Loop – automatic control.
- Open Loop – manual control.
- Feedback control is error correction following a disturbance.
- Feedforward control is control of disturbances, which could cause a process error.

Note



### 3.2 ON/OFF CONTROL

**Figure 3**  
**Typical On/Off Control Scheme**

Let us consider our level control system in a little more practical detail. The valve in the inflow line to the system is an electrically operated solenoid valve. (Remember an electrically operated solenoid valve has only two operating positions – fully open or fully closed.) Assume that under initial conditions with a demand on the system the level will start to fall and  $V_1$  will have to be opened to provide an inflow. This can easily be achieved by mounting a differential pressure switch, P1 at the bottom of the tank to operate when the level falls to  $L_1$ . When the level is at  $L_1$  the liquid will be height  $h_1$  above switch. The pressure at the switch will be  $P_1 = \rho gh_1$ .

$\rho$  – the mass density of the liquid

$g$  – the acceleration due to gravity

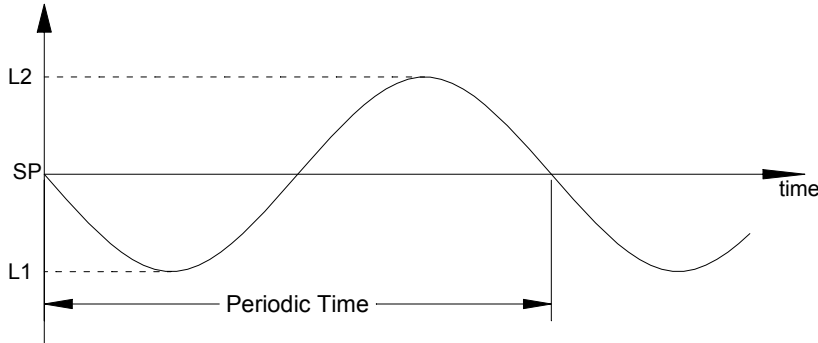
$h_1$  – the height of the liquid

The resulting switch closure can energize the solenoid valve  $V_1$  causing an inflow to the tank. Assuming the valve is correctly sized, this will cause a rise in the level back towards the setpoint.

In order to arrest the rise in level the built in differential feature of the switch can be employed to de-energize the solenoid valve when level  $L_2$  is reached. This system will achieve a mean level in the tank about the desired setpoint. This method is known as ON/OFF control. Clearly it is impossible to maintain the system at the setpoint since there must be a difference in the operating levels  $L_1$  and  $L_2$  as the valve can only be

energized or de-energized. It is often counter productive to try to reduce the differential between  $L_1$  and  $L_2$  to too small a value as this will result in excessive cycling, and hence wear, of the valve. Usual practice is to control with a deadband about the setpoint as shown in Figure 4.

Note



**Figure 4**  
**Typical On/Off Response**

The sinusoidal cycling is typical of on/off control. on/off control can be used to advantage on a sluggish system, i.e., where the periodic time is large. Typical uses in CANDU units are electric heater controls in de-aerator tanks and PHTS bleed condenser and pressurizer.

If fine control is required a simple on/off control system is inadequate. We will discuss a method for achieving a finer control in the next section.

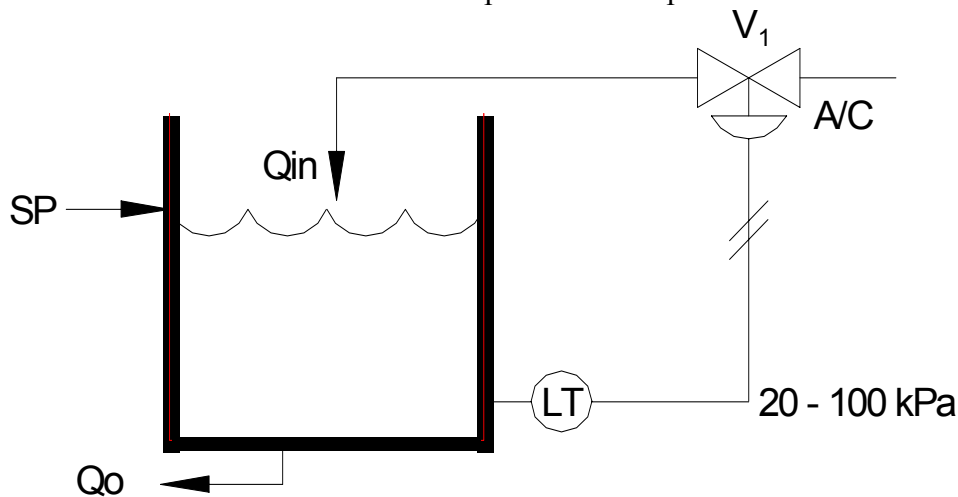
### 3.2.1 Summary

- On/off control - control signal is either 0% or 100%
- Control at setpoint not achievable, a deadband must be incorporated.
- Useful for large, sluggish systems particularly those incorporating electric heaters.

### 3.3 BASIC PROPORTIONAL CONTROL

Note

In our example of on/off control it was seen that an all or nothing control correction was applied as the result of an error signal occurring. Clearly it would be to our advantage if the control signal were proportional to the magnitude of error. This is the basis of proportional control and is the most frequently encountered control mode. How can this control be achieved? Referring to Figure 5 it can be seen that we can modify our system to use a pneumatically operated control valve and a level transmitter with a 20 – 100 kPa pneumatic output.



**Figure 5:** Level Control of Open Tank

If the outflow ( $Q_o$ ) increases then the level in the tank will fall. The pressure sensed by the level transmitter, which is representative of the level in the tank, will also fall causing a decrease in the output signal from the level transmitter. This output signal is fed to the (air to close) control valve (valve fully open with 20 kPa signal, fully closed with 100 kPa signal). A falling level will therefore cause the valve to progressively open and hence raise the level in the tank. The system as shown is somewhat impractical as the initial setpoint conditions will need to be set by some manual method and then ensuring that steady state conditions are achieved with the valve at, say 50% opening and a level transmitter output of 60 kPa (50% range).

This simple system does illustrate however a major disadvantage with proportional control. Notice that the control signal (valve opening) can only change when the level signal is changing. Thus if a disturbance occurs, say an increase in demand, the level will drop and the output from the level transmitter will also fall. This will cause the air to close valve to open more, hence increasing the inflow.



After a period of time the inflow will have increased such that a new mass balance is established between inflow and outflow. But where is the level at this time?

Note

Certainly not at the setpoint. In the example given it will stabilize at some steady state level below the setpoint. This steady state deviation is known as offset and is inherent in all proportional control systems. Despite this obvious disadvantage, (we cannot return the process to the setpoint after a disturbance with proportional control) this mode of control will form the basis for all our control strategies. In the next section we will discuss a more practical control scheme using proportional control and also ways of lessening the problem of offset.

### Example 1

A tank has inflow and outflow equal to 50% of maximum and its level is at the setpoint, say 50%. A step change in outflow occurs to 60% (+10%). Outflow now exceeds inflow so the level will fall. The output from the level transmitter will also fall and, for our system, will match the fall in level – say 1% change in signal for a 1% change in level. The LT signal will open the A/C valve more, by 1% in fact. The inflow is now 51%, still less than the outflow. The level will continue to fall until inflow equals outflow, i.e., (60%). This can only happen when the LT signal has changed by 10% and this change reflects a drop in level on 10%: i.e., 10% offset.

To restore the process to the setpoint requires a further increase of inflow. This increase can only be achieved by a further decrease in signal to the valve (i.e., as decrease in LT output corresponding to a further decrease in level).

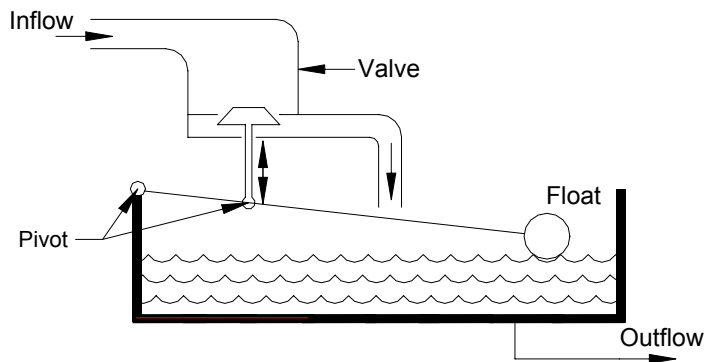
With the conditions as stated in the example there is no way in which a 50% level can be achieved with a 60% outflow. A 50% level with a 60% outflow requires a 60% inflow. Our systems can only provide a 60% inflow from a 40% level signal.

### Example 2

An alternative method of illustrating proportional control is by means of a simple float system (Figure 6). Assume the inflow and outflow are equal and the level is at the setpoint. If an increase in outflow occurs the level in the tank must fall. The float will also fall as the level falls. This drop in float position will cause the valve on the inflow to open more thus increasing the inflow. Eventually the fall in level will result in a valve opening, which will restore the mass balance between the inflow and the outflow.

Note an increased inflow can only be achieved as a result of a lower level in the tank. The level is no longer at the setpoint an offset has been generated.

Note



**Figure 6**  
**Simple Proportional Control**

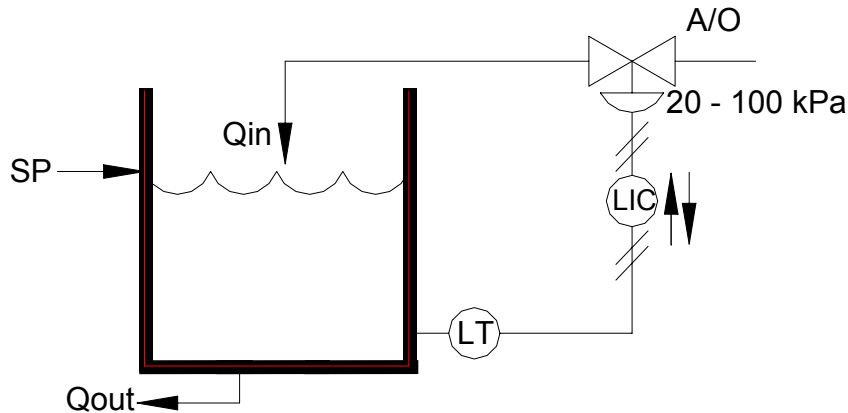
### 3.3.1 Summary

- Proportional control provides a control signal, proportional to the magnitude and direction of the error signal.
- After a disturbance, proportional control will provide only a new mass balance situation. A change in control signal requires a change in error signal, therefore offset will occur.
- Proportional control stabilizes an error; it does not remove it.



In our example of an open tank with a valve on the inflow it would be reasonable to assume that the valve should close in the event of an air supply failure to prevent the tank overflowing, i.e., an air to open valve.

Note



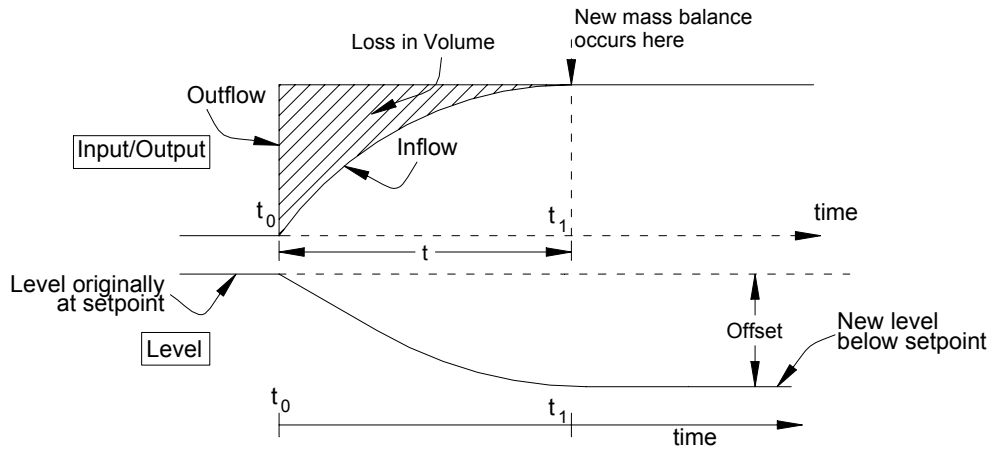
**Figure 7**  
**Open Tank Control**

To achieve the necessary control action on, say, a falling tank level it is necessary to convert the decreasing output of the level transmitter to an increasing input signal to the control valve. The level controller will perform this function and is termed an indirect or reverse acting ( $\uparrow\downarrow$ ) controller. It can be seen that if the valve action had been chosen air to close, then this reversal would not have been required and a direct ( $\uparrow\uparrow$ ) acting controller could have been used. Normally controllers are capable of performing either control action, direct or reverse, by a simple switching process.

The controller will also accept our desired setpoint input and perform the comparison between setpoint and measurement to calculate the error's magnitude and direction.

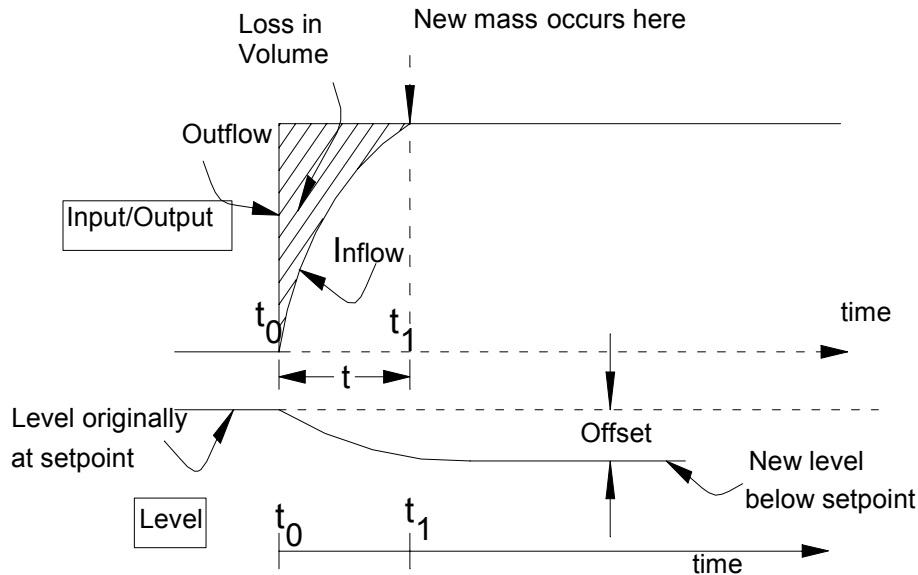
Up to now we have only assumed proportionality constant or one, i.e., the control signal equals the input error. Is this always the best ratio? Consider the following graphs of input, output and level with respect to time:

Note



**Figure 8:** Proportional Control Response Curve

It can be seen that a step increase in demand (outflow) has occurred at time  $t_0$ . the resulting control correction has caused a new mass balance to be achieved after some time  $t_1$ . At this time, under the new mass balance conditions, the level will stabilize at some level below the original setpoint, i.e., an offset has occurred, the loss in volume being represented by the shaded area between the input and output curves.



**Figure 9**  
**Proportional Response with a lower Proportional Band**

Consider now the same demand disturbance but with the control signal increased in relative magnitude with respect to the error signal; i.e.,

instead of control signal = error signal, control signal = error signal x gain constant (k). Clearly for any given error signal the control signal will be increased in magnitude, the inflow will be increased, and a new mass balance will be achieved in a shorter time as shown in Figure 9. (If we refer back to our simple ballcock system in section 3.3, it can be seen that the gain could be varied by adjusting the position of the valve-operating link on the float arm.) The offset is much reduced. In instrumentation this adjustment of controller gain is referred to as proportional band (PB).

Proportional band is defined as that input signal span change, in percent, which will cause a hundred percent change in output signal.

For example if an input signal span change of 100% is required to give an output change of 100% the system is said to have a proportional band of 100%. If the system was now adjusted such that the 100% change in output was achieved with only a 50% change in input signal span then the proportional band is now said to be 50%. There is a clear relationship between proportional band and gain. Gain can be defined as the ratio between change in output and change in input.

$$gain = \frac{\Delta output}{\Delta input}$$

By inspection it can be seen that a PB of 100% is the same as a gain of one since change of input equals change in output. PB is the reciprocal of gain, expressed as a percentage. The general relationship is:

$$gain = \frac{100\%}{PB}$$

Example:

What is the gain of a controller with a PB of?

- a) 40%, b) 200%

Answer:

a)  $gain = \frac{100\%}{PB} = \frac{100\%}{40\%} = 2.5$

b)  $gain = \frac{100\%}{PB} = \frac{100\%}{200\%} = 0.5$

What will the PB setting in percent for a controller with gain of?

- a) 3,      b) 0.4

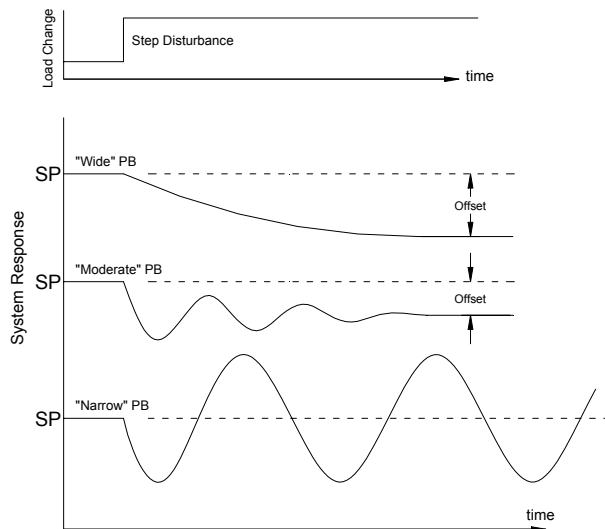
Answer:

$$\text{a) } PB = \frac{100\%}{\text{gain}} = \frac{100\%}{3} = 33.33\%$$

$$\text{b) } PB = \frac{100\%}{\text{gain}} = \frac{100\%}{0.4} = 250\%$$

Small values of PB (high gain) are usually referred to as narrow proportional band whilst low gain is termed wide proportional band. Note there is no magic figure to define narrow or wide proportional band, relative values only are applicable, for example, 15% PB is wider than 10% PB, 150% PB is narrower than 200% PB.

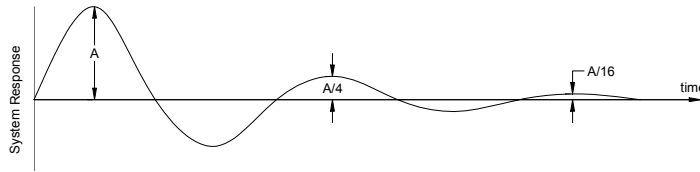
We have seen from the two earlier examples that increasing the gain, (narrowing the PB) caused the offset to be decreased. Can this procedure be used to reduce the offset to zero?



**Figure 10:** Response Versus PB, Proportional Control Only

Note

Note



**Figure 11**  
**1/4 Decay Response Curve**

With reference to Figure 10, consider a high gain system (say gain = 50, PB = 2%). Under steady state conditions with the process at the setpoint the inflow will have a constant value. This is usually taken to be a control signal of 50% for a proportional controller with the process at the setpoint. In other words we have a 50% control capability. With our high gain system it can be seen that the maximum control signal will be achieved with an error of =1% (control signal = gain x error). This control signal will cause the valve to go fully open, the level will rise and the process will cross the setpoint. The error signal will now change sign and when the error again exceeds 1% the resultant control signal will now cause the valve to fully close hence completely stopping the inflow. This process will be repeated continuously – we have reverted to an on/off control situation with all the disadvantages previously mentioned. Obviously there must be some optimum setting of PB which is a trade off between the highly stable but sluggish low gain system with large offset, and the fast acting, unstable on/off system with mean offset equal to zero. The accepted optimum setting is one that causes the process to decay in a 1/4 decay method as shown in both Figures 10 and 11.

The quarter decay curves show that the process returns to a steady state condition after three cycles of damped oscillation. This optimization will be discussed more fully in the section on controller tuning.

Recall the output of a proportional controller is equal to:

$$m = ke$$

where m = control signal

$$k = \text{controller gain} = \frac{100\%}{PB}$$

$$e = \text{error signal} = (SP - M)$$

Clearly if the error is zero the control signal will be zero, this is an undesirable situation. Therefore for proportional control a constant term or bias must be added to provide a steady state control signal when the error is zero.



For the purposes of this course we will assume the steady state output of a proportional controller when at the setpoint to be 50%. The equation for proportional control becomes:

$$m = ke + b$$

where b = bias (=50% added to output signal)

### Calculation of Offset

#### Example:

An air to open valve on the inflow controls level in a tank. When the process is at the setpoint the valve opening is 50%. An increase in outflow results in the valve opening increasing to a new steady state value of 70%. What is the resulting offset if the controller PB is:

- a) 50%
- b) 25%

#### Answer:

To achieve correct control the controller will be reverse ( $\uparrow\downarrow$ ) acting.

- a) PB = 50%  $\therefore$  gain = 2  
Change in valve position = 70 – 50 = 20%  
This is the output change from the controller

$$gain = \frac{\Delta output}{\Delta input}$$

$$2 = \frac{20\%}{\Delta input}$$

$$\therefore \Delta input = 10\%$$

Since controller is reverse acting  $\Delta$  measured variable must have been negative, i.e., -10%. This is equal to a + error or a – offset.  $\therefore$  offset = -10% below setpoint.

- b) PB = 25% gain = 4  
 $\therefore$  input = 5%  
offset = -5% below setpoint.

Note that the narrower PB is likely to introduce some degree of oscillation into the system. Hopefully this will be a damped oscillation.

Note

### 3.4.3 Summary

- The controller action must be chosen (either direct ↑↑ or reverse ↑↓) to achieve the correct control response.
- Proportional Band =  $\frac{100\%}{gain}$  or  $gain = \frac{100\%}{PB}$
- The optimum settings for PB should result in the process decaying in a ¼ decay mode.

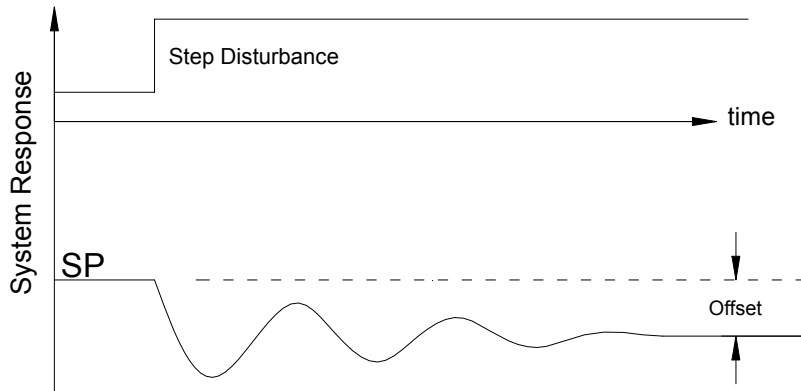
Note

### 3.5 Reset of Integral Action

Note

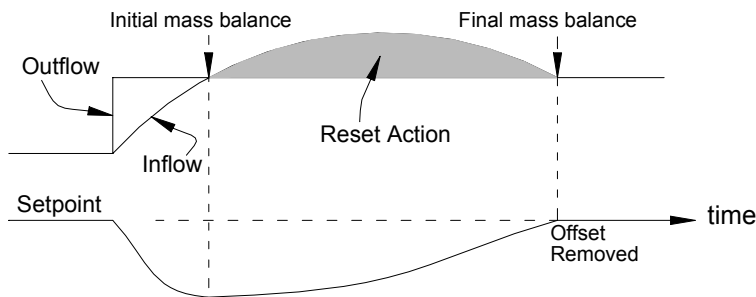
Most of the processes we will be controlling will have a clearly defined setpoint. If we wish to restore the process to the setpoint after a disturbance then proportional action alone will be insufficient.

Consider again the diagram (Figure 12) showing the response of a system under proportional control.



**Figure 12:** Response Curve: Proportional Control Only

If we wish to restore the process to the setpoint we must increase the inflow over and above that required to restore a mass balance. The additional inflow must replace the lost volume and then revert to a mass balance situation to maintain the level at the setpoint. This is shown in Figure 13. This additional control signal must be present until the error signal is once again zero.



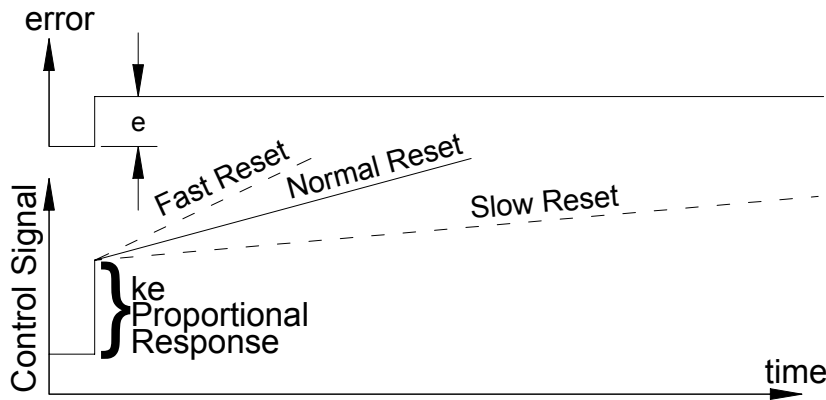
**Figure 13**  
**Additional Control Signal Restores Process to Setpoint**

Note

This additional control signal is known as Reset action, it resets the process to the setpoint. Reset action is always used in conjunction with proportional action. Mathematically, reset action is the integration of the error signal to zero hence the alternative nomenclature – Integral action.

The combination of proportional plus reset action is usually referred to as PI control.

The response of PI control is best considered in open loop form, i.e., the loop is opened just before the final control element so that the control correction is not in fact made. This is illustrated in Figure 14.



**Figure 14**  
**Proportional Plus Reset, Open Loop Response**

It can be seen that proportional action will be equal to  $k_e$  where  $k$  is the gain of the controller. Reset action will cause a ramping of the output signal to provide the necessary extra control action.

After time, say  $t$ , the reset action has repeated the original proportional response; this is the repeat time, the unit chosen for defining reset action. It can be seen that increased reset action would increase the slope of the reset ramp.

Note that proportional action occurs first followed by reset action.

Reset action is defined as either reset rate in repeats per minute (RPM) or reset time in minutes per repeat (MPR).

$$MPR = \frac{1}{RPM}$$

Example:

A direct acting controller has a proportional band of 50% and is subjected to a sustained error. The set point is 50% and the measurement 55%. After 4 minutes the total output signal from the controller has increased by 30%. What is the reset rate setting in RPM and MPR?

Note

Answer:

$$PB = 50\% \qquad gain = \frac{100\%}{50\%} = 2$$

Since  $\uparrow\uparrow k$  will be negative

$$\text{Proportional Signal} = -2 \times \text{error} = -2 \times -5\% = +10\%$$

$$\begin{aligned} \text{Total signal after 4 minutes} &= +30\% \\ &= P + I \end{aligned}$$

$$\therefore \text{Integral Signal} = +20\%$$

i.e., integral action has repeated original proportional signal twice in 4 minutes, 2 repeats per 2 minutes or 0.5 repeats per minute.

$$\begin{aligned} \text{Reset rate} &= 0.5 \text{ RPM or } \frac{1}{0.5} \text{ MPR} \\ &= 2.0 \text{ MPR} \end{aligned}$$

We have already mentioned that the optimum setting for proportional control is one, which produces a  $\frac{1}{4}$  decay curve. What is the optimum setting for reset action? We will discuss this more fully in the module on controller tuning. For now, let us just consider a very slow reset rate and a very fast reset rate.

A very slow reset rate will ramp the control signal up very slowly. Eventually the process will be returned to the setpoint. The control will be very sluggish and if the system is subjected to frequent disturbances the process may not ever be fully restored to the setpoint!

If a very fast reset rate is used, the control signal will increase very quickly. If we are controlling, say, a large volume tank, the level response of the tank may lag behind the response of the controller.

The control signal will go to its limiting value (0 or 100%) and the limiting control signal will eventually cause the process to cross the setpoint. The error signal will now change its sign, and reset action will also reverse direction and quickly ramp to the other extreme.

This process will continue indefinitely, the control valve cycling, with resulting wear and tear, from one extreme to the other. The actual process level will cycle about the setpoint. This cycling is known as reset windup and will occur if the process is subject to a sustained error and a too fast reset rate. The reset rate must be decreased (reset time increased).

The mathematical expression for P + I control becomes:

$$m = k \left( e + \frac{1}{TR} \int edt \right) + b$$

m = control signal

e = error signal (e = SP – M) ∴ (+ or -)

k = controller gain (↑↑ = -) (↑↓ = +)

TR = reset time (MPR)

b = bias signal

Proportional control i.e., (proper sign of gain) inputs a 180° lag into the system (the correction must be opposite to the error). Reset action introduces a further lag. This fact must be taken into account when tuning the controller. (It follows proportional action). The total lag must be increased and is now closer to 360°. (360° lag means the feedback signal is now in phase with the input and adding to it – the system is now unstable.) Reset action causes the loop to be less stable.

### 3.5.1 Summary

- Reset action removes offset.
- It's units are Repeats per Minute (RPM) or Minutes per Repeat (MPR)
- If reset action is faster than the process can respond, Reset Windup can occur.
- Reset Action makes a control loop less stable.

- Do not subject process loops with reset control to sustained errors – the control signal will be ramped to the extreme value – reset windup will occur.

Note

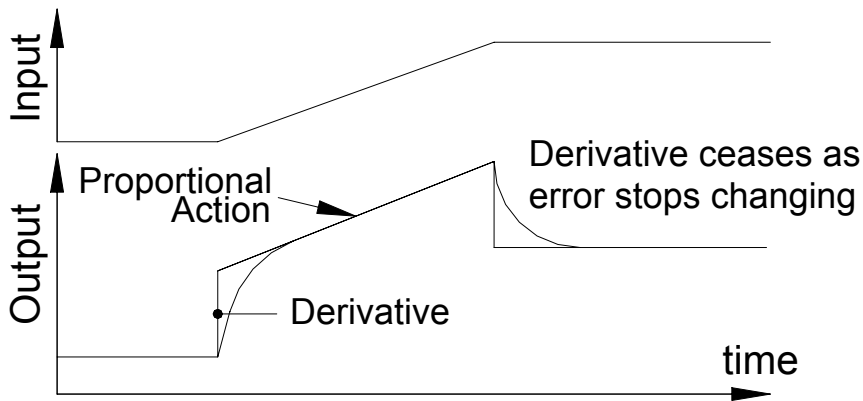
### 3.6 RATE OR DERIVATIVE ACTION

Consider a control system subjected to a disturbance, which causes the error to increase in a ramped manner. Proportional control would respond to this ramped error with a similarly ramped output signal whose slope is proportional to the controller gain. We could reduce the final deviation from the setpoint, i.e., the offset, and the recovery time, if we can provide some extra control signal related to the rate of change of the error signal. This is termed rate or derivative action and is usually incorporated with proportional control.

Rate action is an anticipatory control, which provides a large initial control signal to limit the final deviation. The typical open loop response is shown in Figure 15.

It can be seen that the derivative action gives a large, immediate, control signal, which will limit the deviation. Proportional action is then superimposed upon this step. When the error stops changing derivative action ceases. Note that the displayed step response unobtainable in practice because the normal response approximates and exponential rise and decay.

The rate response gives an immediate control signal, which will be equal to what the proportional response would be after some time, say,  $T$  minutes. Derivative units are given in minutes. These are the minutes advance of proportional action. Derivative action is a leading control and, therefore, tends to reduce the overall lag in the system – the system is somewhat more stable.



**Figure 15**  
**Proportional and Derivative—Open Loop Response**

Note



Mathematically proportional plus derivative (PD) control is expressed as:

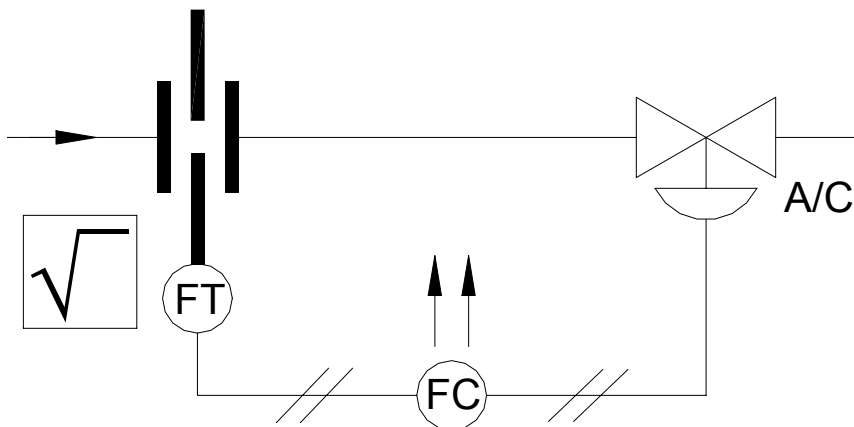
$$m = k \left( e + T_D \frac{de}{dt} \right) + b$$

- m = controller signal
- k = controller gain
- $T_D$  = derivative time
- e = error
- b = bias signal

The use of derivative control is limited. At first glance, derivative control looks attractive. It should help reduce the time required to stabilize an error. However, it will not remove offset. The control signal from derivative action ceases when the error stops changing, which will not necessarily be at the setpoint.

Its use, in practice, is also limited to slow acting processes. If used on a fast acting process, such as flow, control signals due to derivative action will often drive the control valve to extremes following quite small but steep (large  $\frac{de}{dt}$ ) changes in input.

Consider a simple flow control system, consisting of an orifice plate with flow transmitter and square root extractor plus direct acting controller and air to close valve (refer to Figure 16). This system is subjected to a small, but fast, process disturbance. How will this control scheme perform under proportional and derivative control modes?

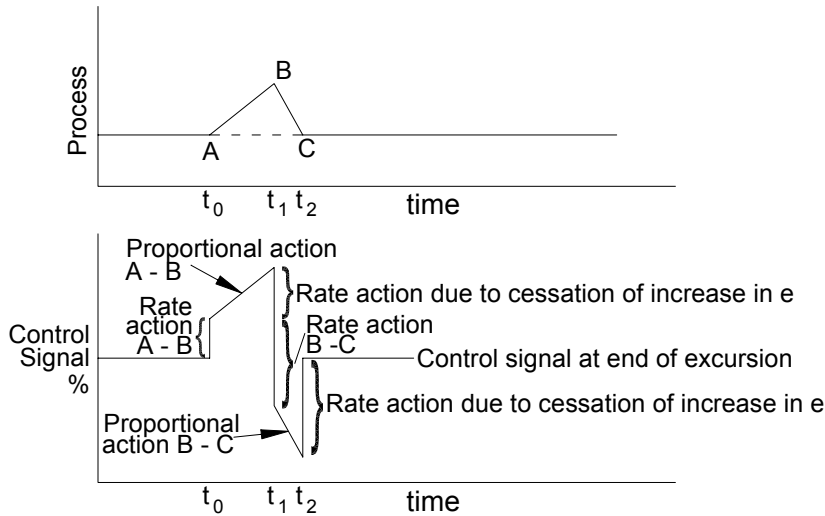


**Figure 16**  
**Simple Flow Control System**

Note

To answer this question, let us consider the PD response to a fast change in process signal in an open loop system (Figure 17).

Note



**Figure 17:** The open Loop Response of Proportional Plus Derivative (PD) Action to Rapidly Changing Error Signals

The upper portion of Figure 17 shows a positive process excursion, AB, from the zero error condition, followed by an equal negative excursion, BC, which returns the error to zero. Note that the rate of change, i.e., the slope of the process change, from B to C is twice the rate of change of the process, from A to B. Mathematically:

$$\frac{de}{dt}(B - C) = 2 \frac{de}{dt}(A - B)$$

The proportional control action from B to C will be equal but opposite to the proportional control action from A to B. The rate or derivative control action from B to C will be double that from A to B. The resulting open loop control signal pattern is shown in the lower portion of Figure 17. The controller gain and derivative settings remain constant.

Very shortly after time ( $t_0$ ) the control signal increases abruptly to a value determined by the rate of change of the error ( $e$ ), the derivative or rate time setting, and the controller gain. Proportional action ramps the control signal up, until time ( $t_1$ ), to a value determined by the error ( $e$ ) and the controller gain setting. This includes the direction of the error and controller action.

At time ( $t_1$ ) the rate of change of the process error,  $de/dt$ , momentarily becomes zero, so the original change in the control signal due to the rate action drops out. Then, the process error change direction becomes negative, and the derivative control action now produces an abrupt

negative control signal, double the original derivative control signal. The proportional control action then ramps the control signal down until time ( $t_2$ ).

Note

At time ( $t_2$ ) the rate of change of the process error becomes zero, so the derivative control signal again drops out leaving the control signal at its original bias (zero) error value. Note that this final bias, (zero) error value of the control signal and, hence, the control valve position at the end of this excursion, is determined solely by the proportional. The valve has been stroked rapidly and repeated by the derivative action subjecting it to unnecessary wear, with no improvement in control.

The response of the closed loop shown in Figure 16 would be somewhat different because the resulting valve action would continuously alter the error signal. However, the valve would still be subjected to rapid and repeated stroking unnecessarily.

Thus, it can be seen from the above discussion that the use of derivative action on fast acting processes such as flow is not advisable.

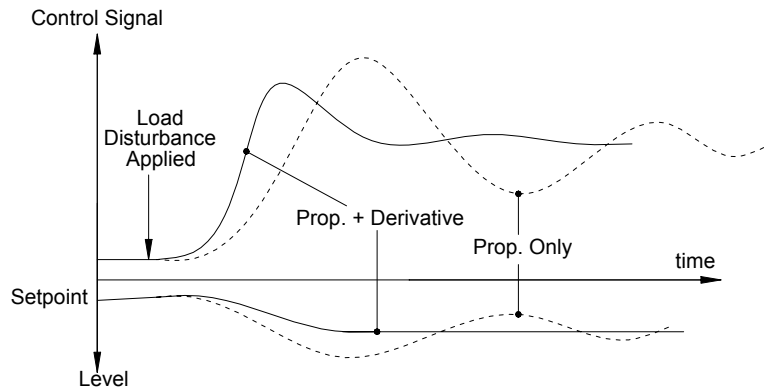
Let us look at the control of a sluggish (generally a physically large) system. As an example, consider a large tank with a variable outflow and a control valve on the inflow. A large volume change will, therefore, be necessary before any appreciable change in level occurs.

Consider a large change in the outflow. After some delay (due to the sluggishness of the system) the controller will respond.

If we have only proportional mode on the controller the delays will mean that the controller is always chasing the error initiated by the outflow disturbance. The response to proportional control is shown in Figure 18. Note that the process has not fully stabilized after a considerable period of time.

The addition of derivative action, however, causes an anticipatory response. The control signal increases more rapidly and the process is returned to a steady state in a much shorter time. Note also that:

The system is more stable (less cycling) with PD control. Offset still exists.



Note

**Figure 18**  
**Large System Under Proportional and Proportional Plus Derivative Control**

### 3.6.1 Summary

- Derivative or rate action is anticipatory and will usually reduce, but not eliminate, offset.
- Its units are minutes (advance of proportional action).
- It tends to reduce lag in a control loop.
- Its use is generally limited to slow acting processes.

### 3.7 MULTIPLE CONTROL MODES

Note

We have already discussed some of the possible combinations of control modes. These are:

Proportional only,

Proportional plus reset (integral) P + I,

Proportional plus derivative (rate) P + D.

It is also possible to use a combination of all three-control modes, Proportional plus Integral plus Derivative (P + I + D).

At a glance proportional only does not appear very attractive – we will get an offset as the result of a disturbance and invariably we wish to control to a fixed setpoint.

An application of proportional only control in a CANDU system is in the liquid zone level control system. The reason that straight proportional control can be used here is that the controlled variable is not level but neutron flux. The manipulated variable is the water level; therefore offset is not important as the level is manipulated to provide the required neutron flux.

In general it can be said that the vast majority of control systems (probably greater than 90%) will incorporate proportional plus integral modes. (We usually want to control to a fixed setpoint.) Flow control systems will invariably have P + I control.

Derivative control will generally be limited to large sluggish systems with long inherent control time delays, (for example, that shown in Figure 18.). A good general example is the heat exchanger. The thermal interchange process is often slow and the temperature sensor is usually installed in a thermal well, which further slows the control signal response. Frequently heat exchanger temperature controllers will incorporate three-mode control (P + I + D).

## 3.8 TYPICAL NEGATIVE FEEDBACK CONTROL SCHEMES

Note

### 3.8.1 Level Control

In general we can divide level measurement into three types:

Open Tanks

Closed Tanks

#### **Bubbler Systems (Open or Closed Tanks)**

If a differential pressure transmitter is used as a level detector, the low-pressure port will be vented to atmosphere in an open tank application. In a closed tank, where there is often a gas phase at pressure above the liquid, the low-pressure port will be taken to the top of the tank. Any gas pressure will then be equally sensed by the high and low sides and thus cancelled.

Remember the closed tank installation will have either a wet or dry leg on the low-pressure sides.

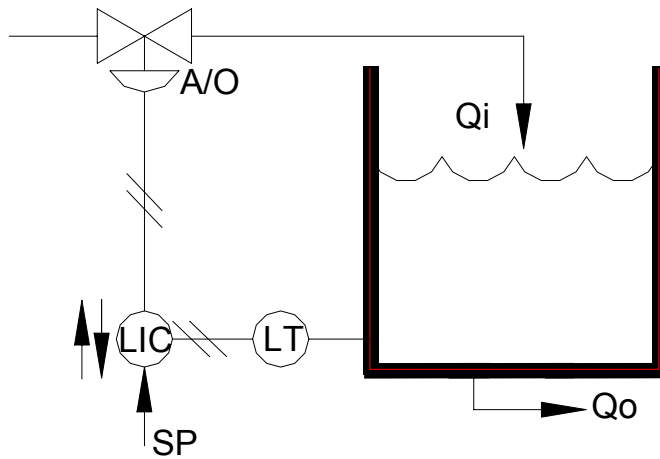
#### **Open Tank Installation**

Assuming the control valve is on the inflow, the best failure mode for the valve would be to fail closed, i.e., Air to Open (A/O) valve. The pressure sensed at the base of the tank on a falling level will decrease, i.e., controller input. The valve must open more, to replenish the tank, requiring an increasing signal. The controller must be reverse acting and will usually have P + I modes. The system is shown in Figure 19

If it is necessary to mount the valve in the outflow, the best failure mode would probably be to fail open (A/C). This valve action would require an increasing signal to halt a falling tank level, again a reverse acting (P + I) controller is necessary.

The same reasoning would apply to closed tank or bubbler systems, the only difference being in the sensing method employed. Remember control modes use of derivative action on large, slow, systems.

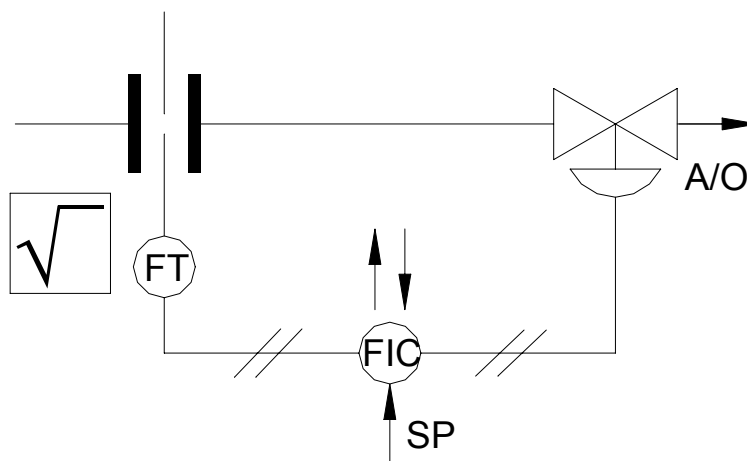
Note



**Figure 19**  
**Open Tank Level Control**

### 3.8.2 Flow Control

A typical flow control system requires some form of restriction to provide a pressure differential proportional to flow (e.g. orifice plate) plus a square root extractor to provide a linear signal. The controller action depends upon the choice of control valve. If an air to open valve is chosen then controller action should be reverse, as an increase in flow must be countered by a decrease in valve opening. For an air to close valve the action must of course be direct. The general format is shown in Figure 20.



**Figure 20**  
**Typical Flow Control**

The control modes will be proportional plus integral (never use derivative on a flow control loop).

Note

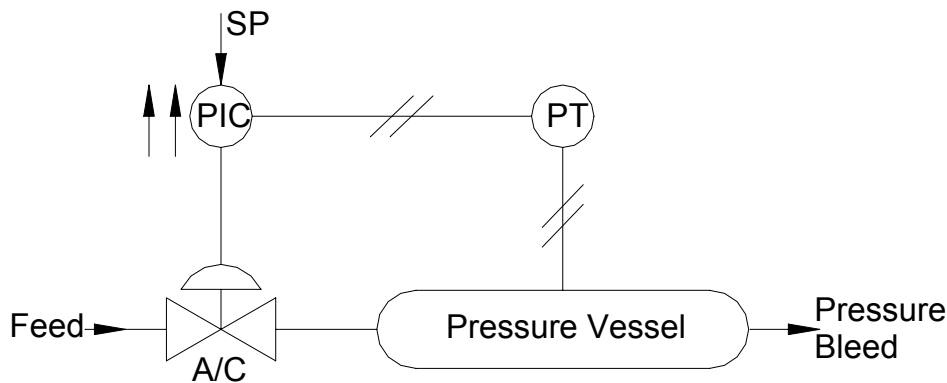
### 3.8.3 Pressure Control

The control of pressure in, say, a pressure vessel, is generally achieved in one of three ways.

1. Variable Feed with Constant Bleed
2. Constant Feed with Variable Bleed
3. Variable Feed and Bleed

Consider first Variable Feed and Constant Bleed (Figure 21).

The feed valve action is air to close (A/C). Increasing pressure will require an increasing valve signal to throttle the supply. The (P + I) controller is direct acting. For a variable bleed application the control valve will be transferred to the bleed application the control valve will be transferred to the bleed line and will need to be A/O if a direct acting controller is used.

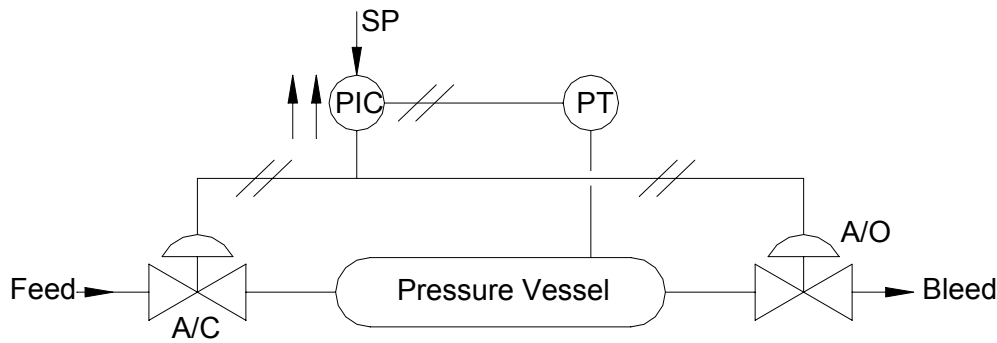


**Figure 21**  
**Pressure Control – Constant Bleed**



For variable feed and bleed we can use a split range control scheme (one controller driving two valves). This is shown in Figure 22. When at the setpoint we require feed to equal bleed. If pressure increases we require less feed action and more bleed action and vice versa. The valve actions must therefore be opposite, say feed valve A/C and bleed valve A/O. On increasing pressure the direct acting controller will supply a larger signal to the feed valve (closing it) and to the bleed valve (opening it). Pressure should thus be maintained at the setpoint with proportional plus integral control.

Note

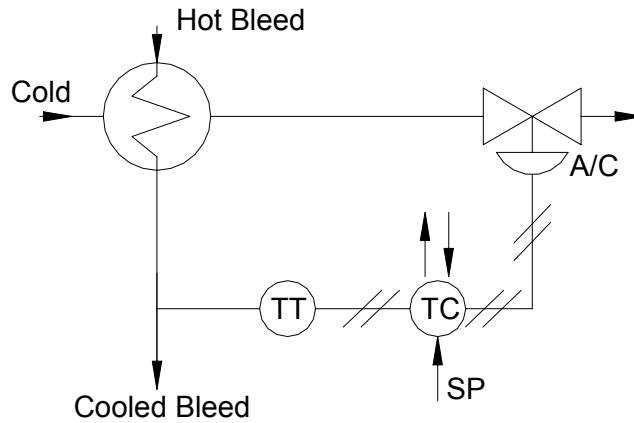


**Figure 22**  
**Split Ranged Feed and Bleed Pressure Control**

### 3.8.4 Temperature Control

The general problem with temperature control is the slowness of response. For this reason the use of derivative action is fairly standard. Figure 23 shows a representative heat exchanger, which cools hot bleed with cold service water.

The choice of control valve would probably be air to close, i.e., fail open, to give maximum cooling in the event of a air supply failure to the valve.



Note

**Figure 23**  
**Temperature Control of a Heat Exchanger**

An increase, say, in bleed temperature requires a larger valve opening, i.e., smaller valve signal. A reverse acting controller is required. Three mode, P + I + D, control is fairly usual.

## REVIEW QUESTIONS - CONTROL

Note

1. Consider a system for heating a room with electric heaters; what are the controlled and manipulated variables.
2. Sketch and label a block diagram of simple process under negative feedback control. Mark setpoint, measurement, error, output, disturbances.
3. State the three important characteristics of negative feedback control.
4. State the differences between feedback and feedforward control.
5. Is driving a car (in a reasonably normal manner) an example of feedback or feedforward control? Explain.
6. Explain the operation of a process under negative feedback on/off control.
7. Why will on/off control cause cycling about the desired setpoint?
8. Why is on/off control frequently used in room heating applications?
9. If in figure 5, we located our control valve in the outflow line, what would be the required valve action for negative feedback proportional control?
10. Explain the relationship between error and controller output in a proportional controller.
11. Why does offset occur with proportional control?
12. A control scheme consists of an open tank with an air to close valve on the outflow. Sketch a simple schematic diagram showing the controller action. What would happen to the control of the system if the valve was changed to air to open but the controller action was unchanged?
13. Why can offset not be removed by narrowing the proportional band?
14. What gain is represented by a Proportional Band of 200%, 75%, 400%, 20%?
15. A disturbance causes a process to change by 5%. What will be the change in controller output if the PB is 100%, 50%, 200%?

Note

16. A tank is controlled by an air to close valve on its inflow. When at the setpoint the valve opening is 50% an outflow disturbance causes the valve opening to become 80%. The controller's PB setting is 50%. What is the offset (%)? Assume a linear valve characteristic. Remember an air to close valve requires a decrease in signal to open it further.
17. Sketch and describe the curve which would, in many processes, be the optimum process response following a disturbance.
18. What is the purpose of reset action?
19. What are the units for reset action?
20. What is reset windup?
21. Does reset action make the loop more or less stable?
22. Draw an open loop curve showing the response of a proportional plus reset control system to a step disturbance.
23. A control system with a direct action controller is operating at the setpoint. The controller proportional band is set at 50%. The system is subjected to a disturbance, which creates a positive step error of +6%. The total control output change after 18 minutes is 48%. What is the reset setting in MPR?
24. Using the same control system and control settings as in Question 23, what would be the effect on the system if it had been subjected to a disturbance which caused a step error of -8% for a period of 18 minutes?
25. What is the purpose of rate control?
26. What are the units of rate control?
27. Why should rate control not be used on a fast acting process such as flow?
28. Will rate action remove offset?
29. What is the effect on the rate signal if the error stops changing?
30. Which control setting gives the largest rate signal, 1 minute or 5 minutes? Why?

Note

31. Sketch an open loop response graph for a proportional plus derivative control system subjected to a ramped error signal.
32. A proportional plus derivative control system is subjected to a ramped error of -10% per minute for 1.5 minutes. The PB setting is 100% and the derivative setting is 3 minutes. The controller is reverse acting. Sketch an open loop response curve for the system showing control signal values at 10% intervals, with respect to time.
33. Give a typical control example where straight proportional control can be used.
34. What is the most commonly encountered combination of control modes and why?
35. Why is it advantageous to use derivative action in the temperature control of a heat exchanger?
36. Sketch a level control scheme for an open tank. The valve selected is A/C and on the inflow line. State controller action and modes.
37. A heat exchanger (cooling hot bleed with cold service water) is controlled by an air to open valve on the service water line. Sketch the circuit showing controller action. What control modes would be used and why?
38. Sketch a simple electronic control scheme for the control of flow. The valve chosen is air to close; an orifice plate develops the differential pressure. Show controller action and state the most likely control modes.